









PREMIUM

Blending Equipment

U.S. Product Catalog



TABLE OF CONTENTS

	COMMERCIAL PRODUCTS	3
	COVERED BEVERAGE BLENDERS	5
	UNCOVERED BEVERAGE BLENDERS	10
	FOOD PREP BLENDERS	14
	IMMERSION BLENDERS	21
	FROZEN TREAT MIXERS	27
	CONTAINERS	31
	ACCESSORIES & PARTS	46
	ORDERING INFORMATION	54



COMMERCIAL PRODUCTS

Food or beverage, front of house or back, there's a Vitamix machine to suit your menu and your batch sizes. And now, finding the right machine has never been easier. We've divided our machines into categories according to application, so you can quickly identify which product might be right for your business.





COVERED BEVERAGE BLENDERS

Reduced blending noise for superior customer experience

Up to 40 optimized programs for consistent blending

Advance Containers offer maximum efficiency and dripless spouts



UNCOVERED BEVERAGE BLENDERS

Variety of control options and container sizes to choose from

Up to 6 optimized programs with automatic shut-off

For a wide range of blends, from smoothies to frozen drinks to açai bowls



FOOD PREP BLENDERS

Powerful efficiency to shorten prep times in Back of House (BOH) applications

Variable Speed Control achieves precise textures in every dish

Tamper allows continuous blending and tackles dense ingredients



IMMERSION BLENDERS

Five wand sizes designed to handle volumes from 3 to 80 gallons

Powerful motor with unique blade and bell design

Continuous run operation for hands-free blending



FROZEN TREAT MIXERS

Incorporate mix-ins into frozen desserts

Prepare milkshakes using either hard or soft ice cream

Standard or programmed models available

COVERED BEVERAGE BLENDERS



COVERED BEVERAGE BLENDERS



QUICK & QUIET®

THE QUIET ONE®

TOUCH & GO® ADVANCE®

*Delivers Vitamix-quality blends
30% faster than ever before*

*Quiet operation, trusted by the
world's largest chains*

*Noise reduction for
smaller volume shops*

APPLICATIONS

Can process thick or high-volume smoothies, frappés, and milkshakes back-to-back without overheating

Ideal for double and triple batches of smoothies, frappes, juices, milkshakes, and cocktails

Ideal for any blended beverage, including smoothies, frappes, juices, milkshakes, and cocktails

MOTOR

2.7 hp large rotor motor

≈3 hp

≈2.3 hp

INCLUDED CONTAINER

40-ounce Accelerate Container with dual blade assembly

48-ounce Advance Container with Advance blade

32-ounce Advance Container with Advance blade

CONTROLS

40 pre-programmed recipe settings with 10 customizable program buttons

Programmable with kit (sold separately)

1 pulse button with customizable pulse speed

34 pre-programmed recipe settings to customize your 6-button control panel

Programmable with kit (sold separately)

High / Low Pulse

20 pre-programmed recipe settings to customize your 6-button control panel

High / Low Pulse

ACCESSORIES

40-ounce Accelerate Container
48-ounce Aer Blend Container

48- or 32-ounce Advance Containers
48- or 32-ounce Standard Containers
32-ounce Aerating Container

32-ounce Advance Containers
32-ounce Aerating Container
48- or 32-ounce Standard Containers

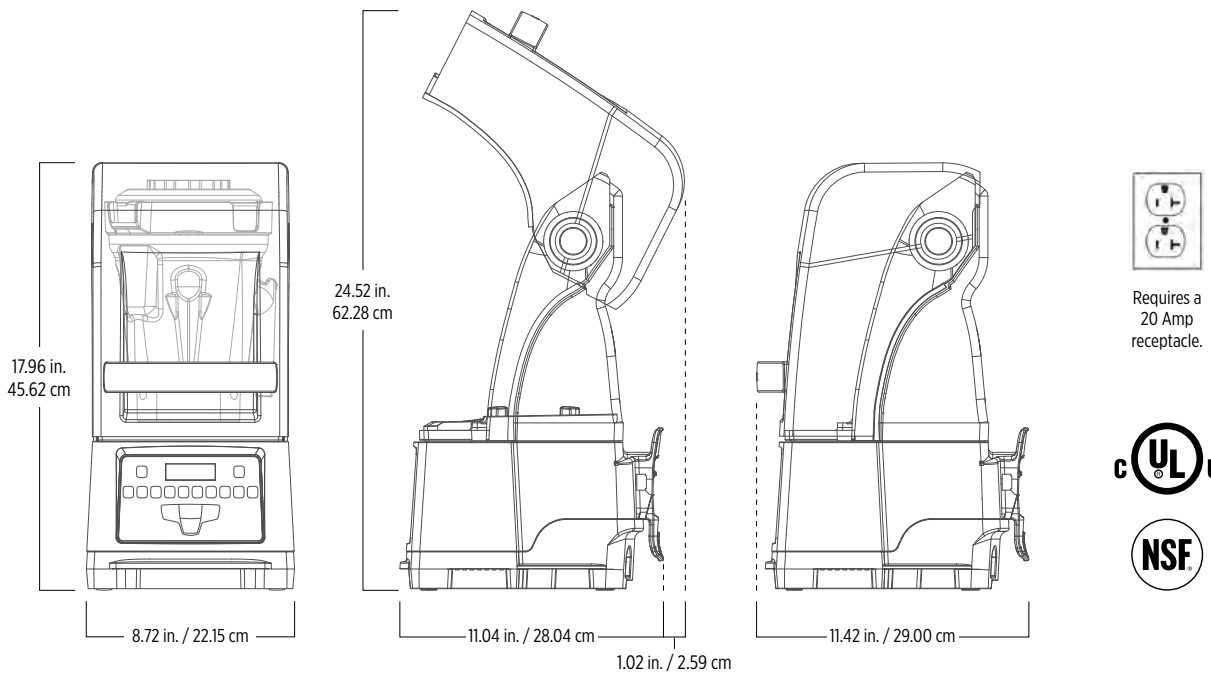

ITEM / MODEL #	DESCRIPTION
----------------	-------------

071771-BPAB / VM0222

Quick & Quiet with 40 oz. / 1.1 L BPA-Free, clear / stackable Accelerate container complete with dual Advance blade assembly and splash lid, removable compact twist lock cover, and 40 programs

SPECIFICATIONS

Programs: 40

Motor: 2.7 horsepower large rotor motor

Electrical: 120 V, 50/60 Hz, 16.0 A

*Requires 20 Amp receptacle

Container & Blade: 40 oz. / 1.1 L Accelerate container complete with Accelerate dual blade assembly and lid

Dimensions (H x W x D):

17.96 x 8.72 x 11.42 in. / 45.62 x 22.15 x 29.00 cm

Height with lid open: 24.52 in. / 62.28 cm

SHIPPING

Pack: 1 per standard pack

Weight: 22.0 lbs.

Carton Dimensions (H x W x D):

13.25 x 12.00 x 19.25 in. / 33.66 x 30.48 x 48.90 cm

WARRANTY

Quick & Quiet is backed by a 700 hour or four-year warranty on motor base parts (whichever comes first) and a one-year warranty on labor. For more complete warranty terms and conditions, please call 1.800.437.4654 or visit Vitamix.com.

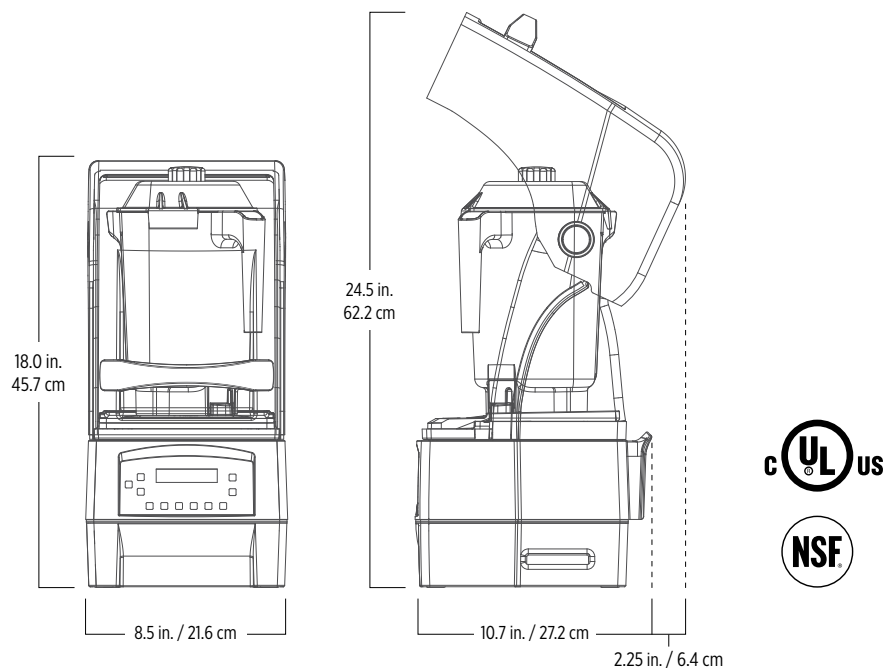

ITEM / MODEL #	DESCRIPTION
----------------	-------------

036019-ABAB / VM0145

The Quiet One with 48 oz. / 1.4 L BPA-Free, clear / stackable Advance Container complete with Advance blade assembly and lid, removable compact twist lock cover, and 34 programs

SPECIFICATIONS

Programs: 34

Motor: ≈3 peak output horsepower motor

Electrical: 120 V, 50/60 Hz, 15.0 A

Container & Blade: 48 oz. / 1.4 L container complete with Advance blade assembly and lid

Dimensions (H x W x D):

18.0 x 8.5 x 10.7 in. / 45,7 x 21,6 x 27,2 cm

Height with lid open: 24.5 in. / 62.2 cm

SHIPPING

Pack: 1 per standard pack

Weight: 22.0 lbs.

Carton Dimensions (H x W x D):

13.25 x 12 x 19.25 in. / 33,7 x 30,5 x 48,9 cm

WARRANTY

The Quiet One is backed by a three-year warranty on motor base parts and a one-year warranty on labor. For more complete warranty terms and conditions, please call 1.800.437.4654 or visit Vitamix.com.

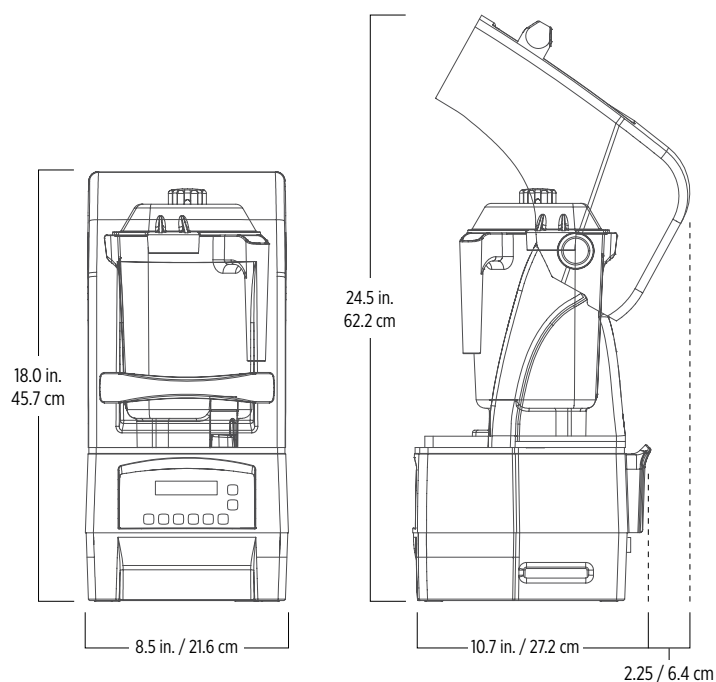

ITEM / MODEL #	DESCRIPTION
----------------	-------------

068255-ABAB / VM0115A

Touch & Go Advance with 32 oz. / 0.9 L BPA-Free, clear / stackable Advance Container complete with Advance blade assembly and lid, and removable compact twist lock cover, and 20 programs

SPECIFICATIONS

Programs: 20

Motor: ≈2.3 peak output horsepower motor

Electrical: 120 V, 50/60 Hz, 12.0 A

Container & Blade: 32 oz. / 0.9 L container complete with Advance blade assembly and lid

Dimensions (H x W x D):

18.0 x 8.5 x 10.8 in / 45.7 x 21.6 x 27.3 cm

Height with lid open: 24.5 in / 62.2 cm

SHIPPING

Pack: 1 per standard pack

Weight: 22.6 lbs.

Carton Dimensions (H x W x D):

19.37 x 11.87 x 13.0 in / 49.2 x 30.2 x 33.0 cm

WARRANTY

The Touch & Go Advance is backed by a three-year warranty on motor base parts and a one-year warranty on labor. For more complete warranty terms and conditions, please call 1.800.437.4654 or visit vitamix.com.

UNCOVERED BEVERAGE BLENDERS





DRINK MACHINE™ ADVANCE®

DRINK MACHINE™ TWO-SPEED

Six blending programs offer custom capabilities for every menu

Easy-to-use controls for consistent drink quality

APPLICATIONS

Ideal for any blended beverage, including smoothies, frappés, juices, milkshakes, and cocktails

Ideal for açai bowls, sorbets, and green smoothies

MOTOR

≈2.3 hp

≈2.3 hp

INCLUDED CONTAINER

48-ounce Advance Container with Advance blade

64-ounce Standard Container with wet blade

CONTROLS

6 programs deliver fast and consistent high-quality beverages

Programmable with kit (sold separately)

Pulse

High / Low

TAMPER

Tamper

ACCESSORIES

48- or 32-ounce Advance Containers

48- or 32-ounce Standard Containers

64 ounce Standard Containers

48- or 32-ounce Standard Containers

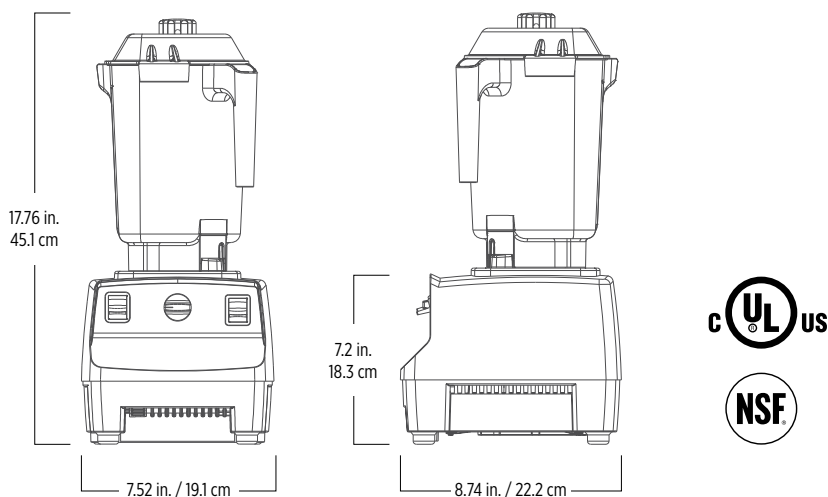

ITEM / MODEL #	DESCRIPTION
062824 / VM0100A	Drink Machine Advance with BLACK base, 48 oz. / 1.4 L BPA-Free clear/stackable Advance Container complete with Advance blade assembly and lid. Includes 6 pre-loaded programs.
062825 / VM0100A	Drink Machine Advance with RED base, 48 oz. / 1.4 L BPA-Free clear/stackable Advance Container complete with Advance blade assembly and lid. Includes 6 pre-loaded programs.

SPECIFICATIONS

Programs: 6

Motor: ≈2.3 peak output horsepower motor

Electrical: 120 V, 50/60 Hz, 11.5 A

Container & Blade: 48 oz. / 1.4 L container complete with Advance blade assembly and lid

Dimensions (H x W x D):

17.76 x 7.52 x 8.74 in / 45.1 x 19.1 x 22.2 cm

SHIPPING

Pack: 1 per standard pack

Weight: 13.26 lbs.

Carton Dimensions (H x W x D):

16.38 x 11.38 x 12.88 in. / 41.6 x 28.9 x 32.7 cm

WARRANTY

The Drink Machine Advance is backed by a three-year warranty on motor base parts and a one-year warranty on labor. For more complete warranty terms and conditions, please call 1.800.437.4654 or visit vitamix.com.

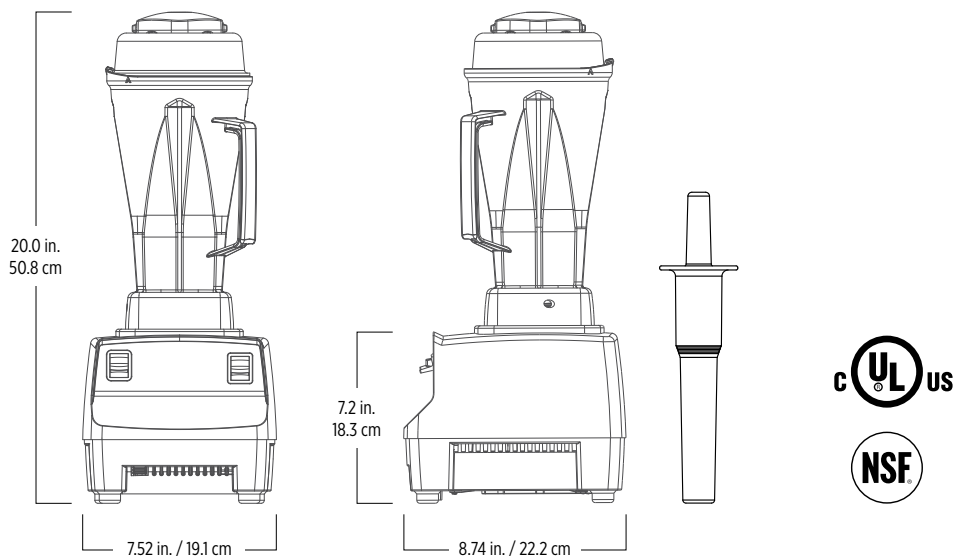

ITEM / MODEL #	DESCRIPTION
----------------	-------------

062828 / VM0100

Drink Machine Two-Speed with 64 oz. / 2.0 L BPA-Free, clear standard container complete with wet blade assembly and lid, tamper, and black base.

SPECIFICATIONS

Motor: ≈2.3 peak output horsepower motor

Electrical: 120 V, 50/60 Hz, 11.5

Container & Blade: 64 oz. / 2.0 L standard container complete with wet blade assembly and lid

Dimensions (H x W x D):

20.0 x 7.52 x 8.74 in / 50.8 x 19.1 x 22.2 cm

SHIPPING

Pack: 1 per standard pack

Weight: 13.4 lbs.

Carton Dimensions (H x W x D):

16.38 x 11.38 x 12.88 in. / 41.6 x 28.9 x 32.7 cm

WARRANTY

The Drink Machine Two-Speed is backed by a three-year warranty on motor base parts and a one-year warranty on labor. For more complete warranty terms and conditions, please call 1.800.437.4654 or visit vitamix.com.

FOOD PREP BLENDERS





POWER-PREP™	VITA-PREP® 3	VITA-PREP®	VITAMIX XL® AVAILABLE THROUGH 2026
<i>Redefining back-of-house blending with unmatched versatility and performance</i>	<i>Exceptional power, performance, and versatility for the most demanding kitchens</i>	<i>Dependable BOH tool to simplify prep work</i>	<i>Our most powerful, largest capacity machine for maximum efficiency</i>
APPLICATIONS			
For the most challenging back-to-back blends in any size from 3 ounces to 1.5 gallons	For difficult back-to-back blending, chopping, puréeing, emulsifying, heating, grinding	Blending, chopping, puréeing, emulsifying, heating, grinding	Large-volume batches, ground proteins, ice cream and gelato bases, aerated batters and whipped creams, dressings and vinaigrettes
MOTOR			
2.7 hp large rotor motor	≈3 hp and larger cooling fan	≈2.3 hp	≈4.2 hp
INCLUDED CONTAINER			
64-ounce Culinary Container 1.5-gallon Big Batch™ Container	64-ounce Standard Container with wet blade	64-ounce Standard Container with wet blade	1.5-gallon XL Container with XL blade and 64-ounce XL Container with XL blade
CONTROLS			
Variable Speed Control Pulse	Variable Speed Control High/Low	Variable Speed Control High/Low	Variable Speed Control (Programs Model available) Pulse
TAMPER			
Tamper	Tamper	Tamper	Tamper
ACCESSORIES			
40-ounce Accelerate™ Container CE 48-ounce Aer Blend Container	64-, 48-, or 32-ounce Standard Containers 32-ounce Aerating Container	64-, 48-, or 32-ounce Standard Containers 32-ounce Aerating Container	1.5-gallon XL Container 64-ounce XL Container

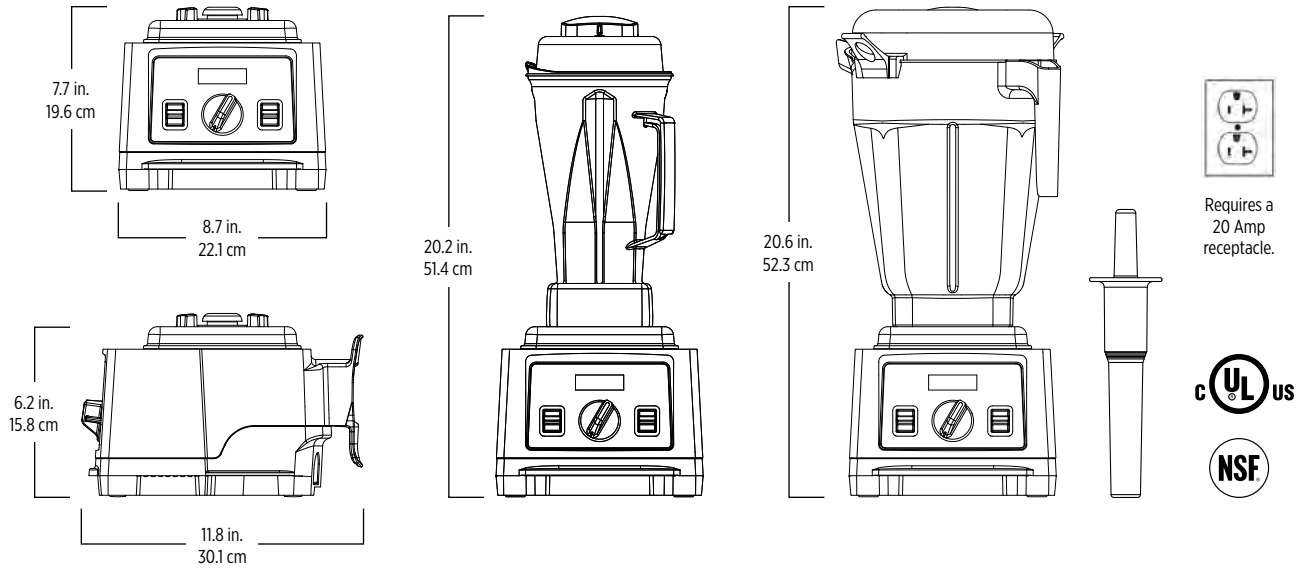

ITEM / MODEL #	DESCRIPTION
075757 / VM0247	Power-Prep with 64 oz. / 2.0 L BPA-Free, clear container complete with wet blade assembly, lid, tamper, and base.
075759 / VM0247	Power-Prep with 1.5 Gal. / 5.6 L BPA-Free, clear container complete with wet blade assembly, lid, tamper, and base.
075760 / VM0247	Power-Prep with 64 oz. / 2.0 L BPA-Free, clear container complete with wet blade assembly, lid, tamper, and base. Also includes 1.5 Gal./5.6 L Big Batch container complete with blade assembly and lid.
075758 / VM0247	Power-Prep motor base only.

SPECIFICATIONS

Motor: ≈2.7 peak output horsepower motor

Electrical: 120 V, 60 Hz, 15 A

This unit requires a 20 Amp receptacle

075757 Container & Blade: 64 oz/2.0 L, wet blade

075759 Container & Blade: 1.5 G/5.6 L, wet blade

075760 Container & Blade: 075757 & 075759

Dimensions (H x W x D):

075758: 7.7 x 8.7 x 11.8 in. / 19.6 x 22.1 x 30.1 cm

075757: 20.2 x 8.7 x 11.8 in. / 51.4 x 22.1 x 30.1 cm

075759: 20.6 x 9.6 x 11.8 in. / 52.3 x 24.4 x 30.1 cm

SHIPPING

Pack: 1 per standard pack

075758 Weight: 13.2 lbs.

075757 Weight: 17.1 lbs.

075759 Weight: 19.5 lbs.

075760 Weight: 23.8 lbs.

Carton Dimensions (H x W x D):

075758: 9.9 x 14.5 x 11.6 in. / 25.1 x 36.8 x 29.5 cm

075757: 15.1 x 14.6 x 11.6 in. / 38.4 x 37.1 x 29.5 cm

075759: 18.1 x 14.4 x 11.6 in. / 46.0 x 36.6 x 29.5 cm

075760: 15.3 x 23.0 x 14.3 in. / 38.9 x 58.4 x 36.3 cm

WARRANTY

The Power-Prep is backed by a 700 hour or four-year warranty on motor base parts (whichever comes first) and a one-year warranty on labor. For more complete warranty terms and conditions, please call 1.800.437.4654 or visit vitamix.com.

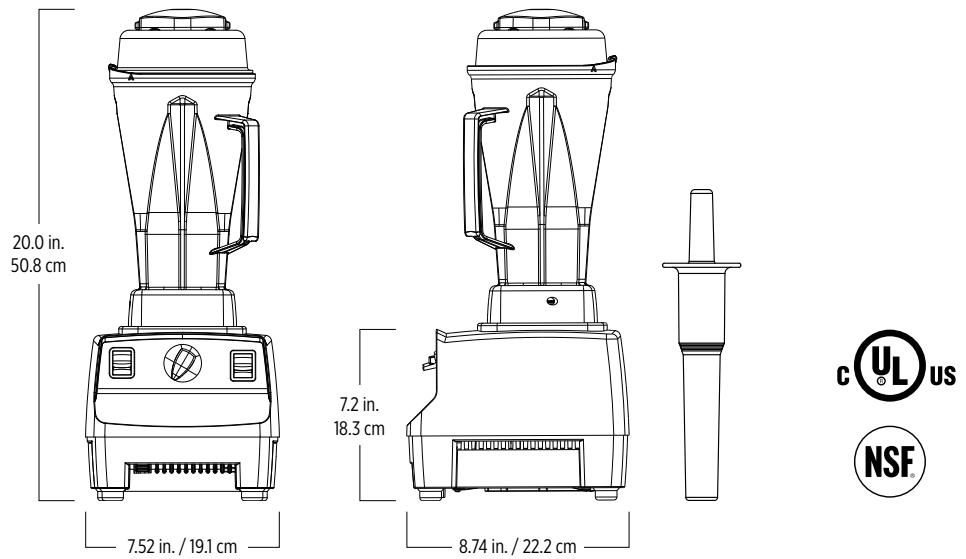

ITEM / MODEL #	DESCRIPTION
----------------	-------------

062826 / VM0101D

Vita-Prep 3 with 64 oz. / 2.0 L BPA-Free, clear container complete with wet blade assembly, lid, tamper, and base.

SPECIFICATIONS

Motor: ≈3 peak output horsepower motor

Electrical: 120 V, 50/60 Hz, 13 A

Container & Blade: 64 oz. / 2.0 L standard container complete with wet blade assembly and lid

Dimensions (H x W x D):

20.0 x 7.52 x 8.74 in / 50.8 x 19.1 x 22.2 cm

SHIPPING

Pack: 1 per standard pack

Weight: 13.8 lbs.

Carton Dimensions (H x W x D):

16.38 x 11.38 x 12.88 in. / 41.6 x 28.9 x 32.7 cm

WARRANTY

The Vita-Prep 3 is backed by a three-year warranty on motor base parts and a one-year warranty on labor. For more complete warranty terms and conditions, please call 1.800.437.4654 or visit vitamix.com.

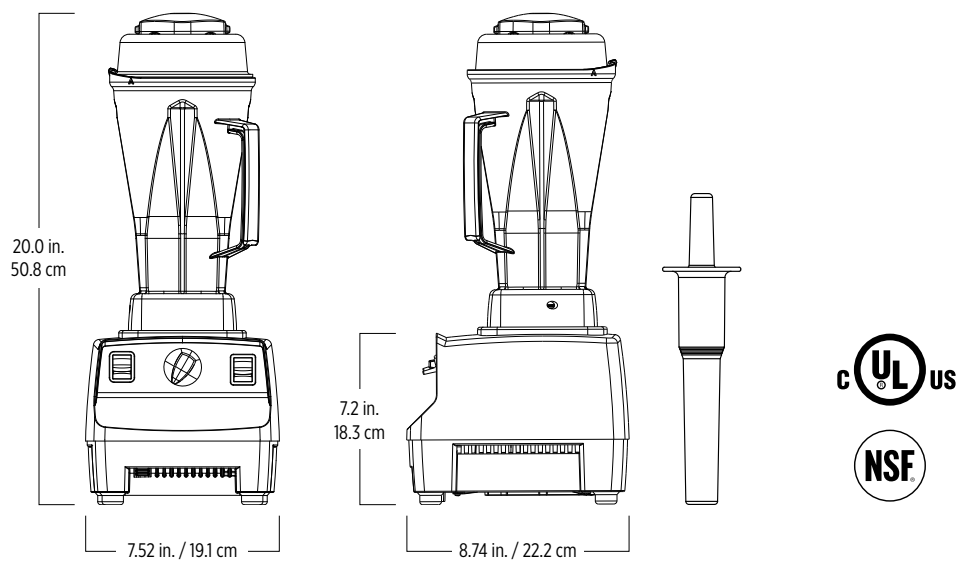

ITEM / MODEL #	DESCRIPTION
062827 / VM0101	Vita-Prep with 64 oz. / 2.0 L BPA-Free, clear container complete with wet blade assembly, lid, tamper, and base

SPECIFICATIONS

Motor: ≈2.3 peak output horsepower motor

Electrical: 120 V, 50/60 Hz, 11.5 A

Container & Blade: 64 oz. / 2.0 L standard container complete with wet blade assembly and lid

Dimensions (H x W x D):

20.0 x 7.52 x 8.74 in / 50.8 x 19.1 x 22.2 cm

SHIPPING

Pack: 1 per standard pack

Weight: 13.8 lbs.

Carton Dimensions (H x W x D):

16.38 x 11.38 x 12.88 in. / 41.6 x 28.9 x 32.7 cm

WARRANTY

The Vita-Prep is backed by a three-year warranty on motor base parts and a one-year warranty on labor. For more complete warranty terms and conditions, please call 1.800.437.4654 or visit vitamix.com.

AVAILABLE THROUGH 2026

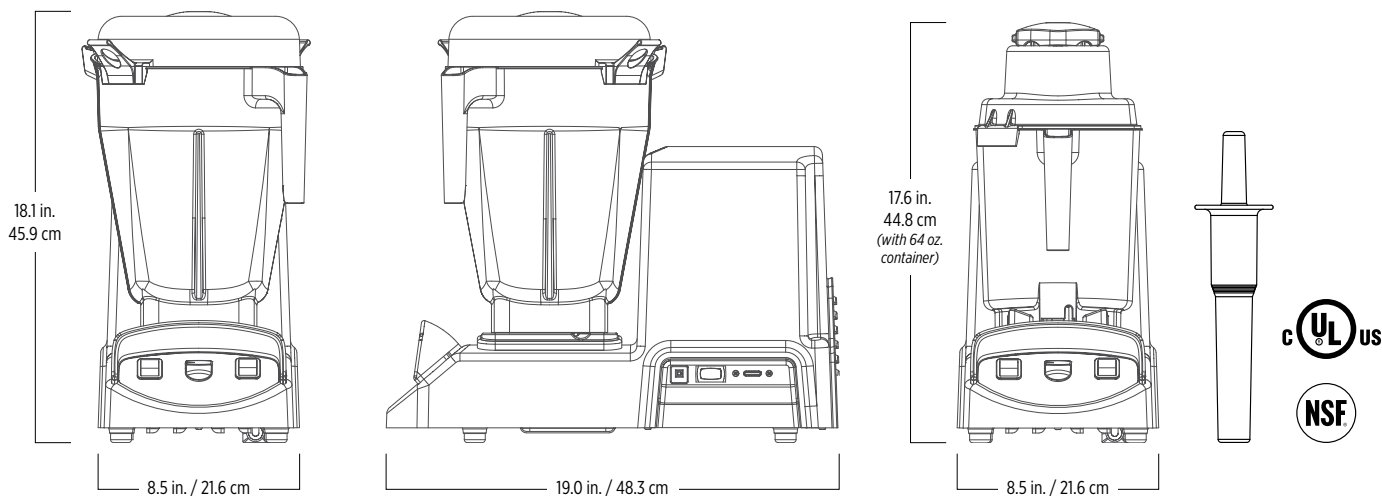

ITEM / MODEL #	DESCRIPTION
005201-1191 / VM0141A AVAILABLE UNTIL LATE 2026	Vitamix XL Variable Speed with 1.5 gal. / 5.6 L container complete with XL blade assembly, lid, and tamper. Also includes 64 oz. / 2.0 L container complete with XL blade assembly and lid.
005205-1550 / VM0141A AVAILABLE UNTIL LATE 2026	Vitamix XL Variable Speed with 1.5 gal. / 5.6 L container complete with blade assembly, lid, and tamper.

SPECIFICATIONS

Motor: ≈4.2 peak output horsepower motor
Electrical: 120 V, 50/60 Hz, 15.0 A
Container & Blade: 1.5 gal. / 5.6 L and 64 oz. / 2.0 L high-impact clear / stackable container complete with XL blade assembly and lid

Dimensions (H x W x D):
 18.1 x 8.5 x 19.0 in. / 45.9 x 21.6 x 48.3 cm

SHIPPING

Pack: 1 per standard pack
Weight: 005201 - 46.4 lbs. • 005205 - 43.2 lbs

Carton Dimensions (H x W x D):
 19.1 x 16.5 x 35.5 in. / 48.5 x 41.9 x 90.2 cm

WARRANTY

The Vitamix XL is backed by a three-year warranty on motor base parts and a one-year warranty on labor. For more complete warranty terms and conditions, please call 1.800.437.4654 or visit vitamix.com.

AVAILABLE THROUGH 2026

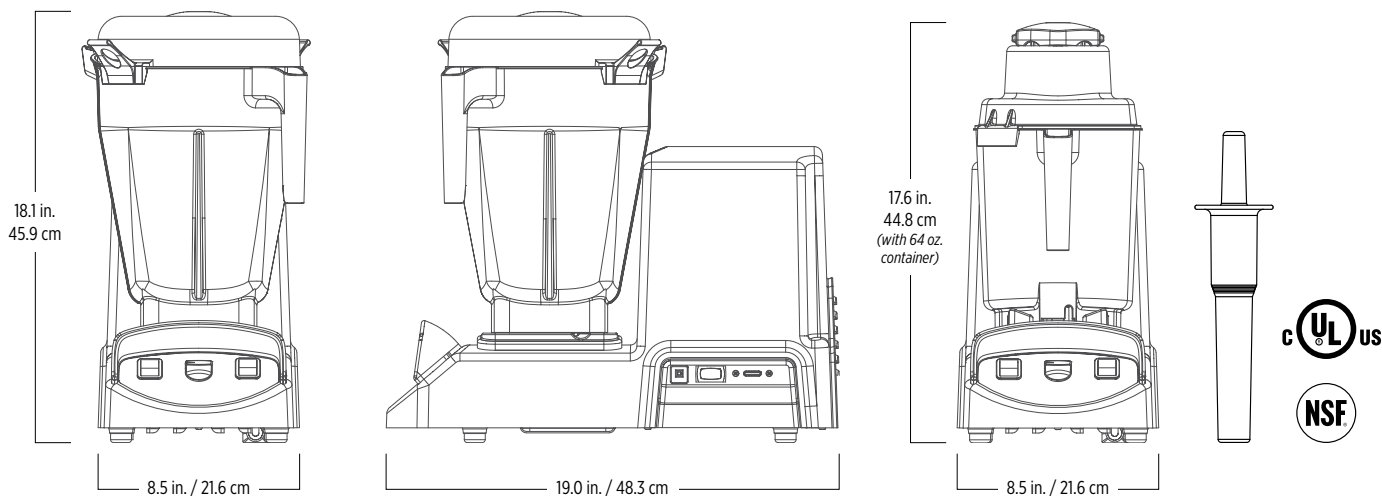

ITEM / MODEL #	DESCRIPTION
005202-1192 / VM0141 <i>AVAILABLE UNTIL LATE 2026</i>	Vitamix XL Programs with 1.5 gal. / 5.6 L container complete with XL blade assembly, lid, and tamper. Also includes 64 oz. / 2.0 L container complete with XL blade assembly, and lid. Includes 6 - preloaded programs.

SPECIFICATIONS

Programs: 6
Motor: ≈4.2 peak output horsepower motor
Electrical: 120 V, 50/60 Hz, 15.0 A
Container & Blade: 1.5 gal. / 5.6 L and 64 oz. / 2.0 L high-impact clear / stackable container complete with XL blade assembly and lid

Dimensions (H x W x D):
 18.1 x 8.5 x 19.0 in. / 45.9 x 21.6 x 48.3 cm

SHIPPING

Pack: 1 per standard pack
Weight: 46.3 lbs.

Carton Dimensions (H x W x D):
 19.1 x 16.5 x 35.5 in. / 48.5 x 41.9 x 90.2 cm

WARRANTY

The Vitamix XL is backed by a three-year warranty on motor base parts and a one-year warranty on labor. For more complete warranty terms and conditions, please call 1.800.437.4654 or visit vitamix.com.

IMMERSION BLENDERS





IMMERSI-PREP 14

IMMERSI-PREP 16

IMMERSI-PREP 18

IMMERSI-PREP 21

IMMERSI-PREP 23

An immersion blender that brings new power, precision, and convenience to professional kitchens

APPLICATIONS

Blending large volumes of salad dressings, soups, sauces, and more

3 to 17 gallon capacity

10 to 28 gallon capacity

15 to 40 gallon capacity

20 to 55 gallon capacity

25 to 80 gallon capacity

MOTOR

≈2.3 hp

CONTROLS

3 speed settings to create a wide range of textures and a variety of different sizes

With Continuous Run Operation, use a light touch to power through high-volume blending jobs without having to hold down a button

ACCESSORIES

Wall mount (included)

Removable blending wands (14", 16", 18", 21", 23" / sold separately)

Whisk attachment (sold separately)

Pot-Clip (sold separately)

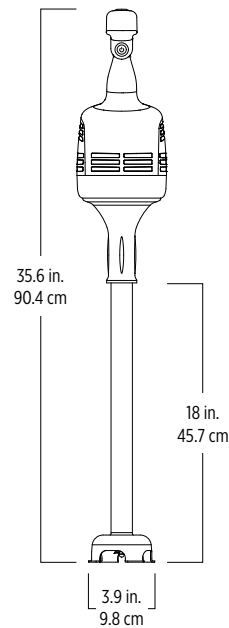
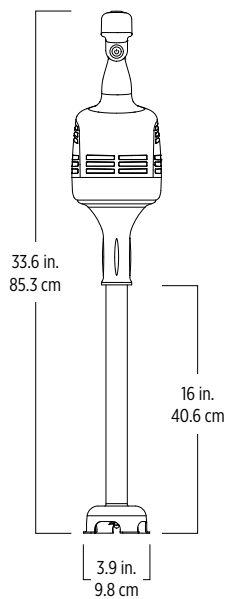
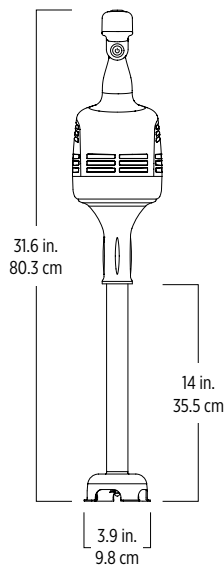
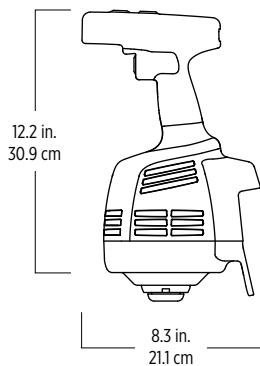
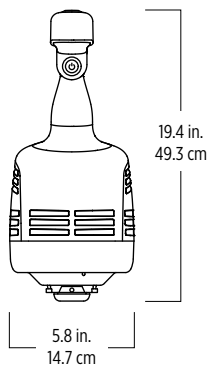

ITEM / MODEL #	DESCRIPTION
073051 ABAP / VM0224	Immersi-Prep 14 with motor assembly, 14-inch blending wand, 12-foot power cord, and wall mount.
075071-ABAP / VM0224	Immersi-Prep 16 with motor assembly, 16-inch blending wand, 12-foot power cord, and wall mount.
075072-ABAP / VM0224	Immersi-Prep 18 with motor assembly, 18-inch blending wand, 12-foot power cord, and wall mount.

SPECIFICATIONS

Motor: ≈2.3 peak output horsepower motor

Electrical: 120 V, 60 Hz, 10.5 A

073051 Attachment: 14-inch Wand

073051 Attachment: 16-inch Wand

075072 Attachment: 18-inch Wand

Dimensions (H x W x D):

073051: 31.6 x 5.8 x 8.3 in / 80.3 x 14.7 x 21.1 cm

075071: 33.6 x 5.8 x 8.3 in / 85.3 x 14.7 x 21.1 cm

075072: 35.6 x 5.8 x 8.3 in / 90.4 x 14.7 x 21.1 cm

SHIPPING

Pack: 1 per standard pack

073051 Weight: 15.9 lbs.

073051 Weight: 16.4 lbs.

075072 Weight: 16.9 lbs.

Carton Dimensions (H x W x D):

073051: 12.8 x 21.4 x 8.9 in. / 32.4 x 54.3 x 22.5 cm

075071: 12.4 x 23.4 x 8.9 in. / 31.4 x 59.4 x 22.5 cm

075072: 12.4 x 25.4 x 8.9 in. / 31.4 x 64.5 x 22.5 cm

WARRANTY

The Immersi-Prep is backed by a one-year warranty. For more complete warranty terms and conditions, please call 1.800.437.4654 or visit vitamix.com.

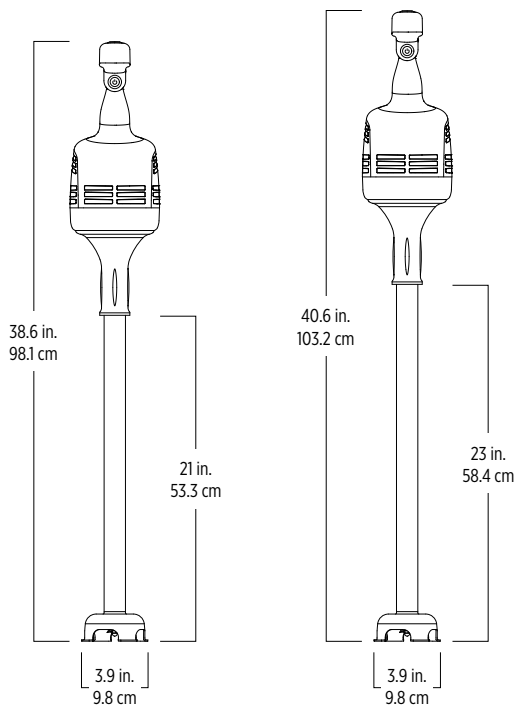
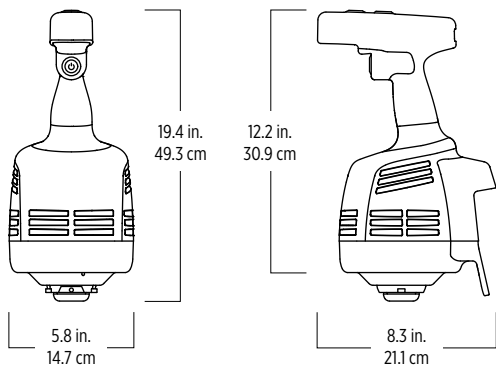

ITEM / MODEL #	DESCRIPTION
075073-ABAP / VM0224	Immersi-Prep 21 with motor assembly, 21-inch blending wand, 12-foot power cord, and wall mount.
075074-ABAP / VM0224	Immersi-Prep 23 with motor assembly, 23-inch blending wand, 12-foot power cord, and wall mount.

SPECIFICATIONS

Motor: ≈2.3 peak output horsepower motor
Electrical: 120 V, 60 Hz, 10.5 A
075073 Attachment: 21-inch Wand
075074 Attachment: 23-inch Wand

Dimensions (H x W x D):
075073: 38.6 x 5.8 x 8.3 in / 98.1 x 14.7 x 21.1 cm
075074: 40.6 x 5.8 x 8.3 in / 85.3 x 14.7 x 21.1 cm

SHIPPING

Pack: 1 per standard pack
075073 Weight: 17.5 lbs.
075074 Weight: 17.9 lbs.

Carton Dimensions (H x W x D):
075073: 12.4 x 28.4 x 8.9 in. / 31.4 x 72.1 x 22.5 cm
075074: 12.4 x 30.4 x 8.9 in. / 31.4 x 77.2 x 22.5 cm

WARRANTY

The Immersi-Prep is backed by a one-year warranty. For more complete warranty terms and conditions, please call 1.800.437.4654 or visit vitamix.com.

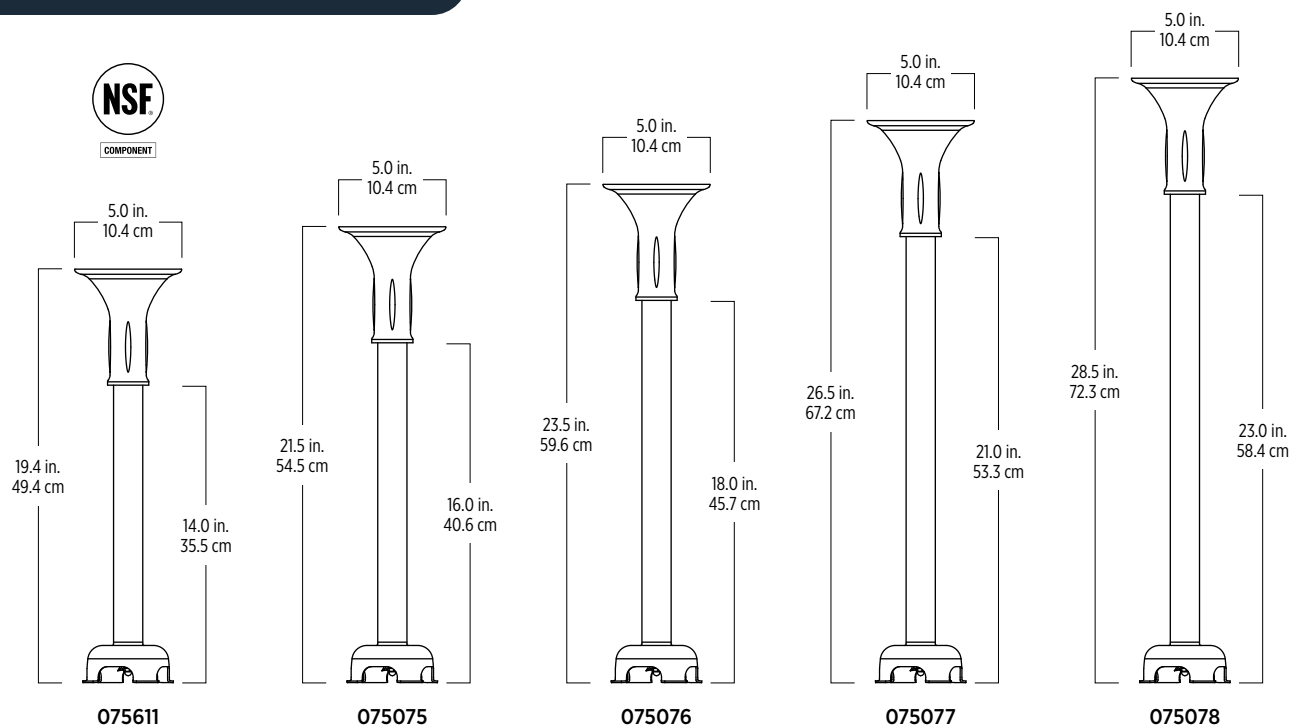

ITEM / MODEL #	DESCRIPTION
075611	Immersi-Prep 14 Wand , includes 14-inch blending wand and Use & Care Manual.
075075	Immersi-Prep 16 Wand , includes 16-inch blending wand and Use & Care Manual.
075076	Immersi-Prep 18 Wand , includes 18-inch blending wand and Use & Care Manual.
075077	Immersi-Prep 21 Wand , includes 21-inch blending wand and Use & Care Manual.
075078	Immersi-Prep 23 Wand , includes 23-inch blending wand and Use & Care Manual.

SPECIFICATIONS

Dimensions (H x W x D):

075611: 19.4 x 5.0 x 5.0 in. / 49.4 x 10.4 x 10.4 cm

075075: 21.5 x 5.0 x 5.0 in. / 54.5 x 10.4 x 10.4 cm

075076: 23.5 x 5.0 x 5.0 in. / 59.6 x 10.4 x 10.4 cm

075077: 26.5 x 5.0 x 5.0 in. / 67.2 x 10.4 x 10.4 cm

075078: 28.5 x 5.0 x 5.0 in. / 72.3 x 10.4 x 10.4 cm

SHIPPING

Pack: 1 per standard pack

075611 Weight: 5.5 lbs.

075075 Weight: 6.2 lbs.

075076 Weight: 6.6 lbs.

075077 Weight: 7.4 lbs.

075078 Weight: 7.8 lbs.

Carton Dimensions (H x W x D):

075611: 5.9 x 20.9 x 5.9 in. / 15.2 x 53.1 x 15.2 cm

075075: 5.9 x 22.9 x 5.9 in. / 15.2 x 58.2 x 15.2 cm

075076: 5.9 x 24.9 x 5.9 in. / 15.2 x 63.2 x 15.2 cm

075077: 5.9 x 27.9 x 5.9 in. / 15.2 x 70.9 x 15.2 cm

075078: 5.9 x 29.9 x 5.9 in. / 15.2 x 75.9 x 15.2 cm

WARRANTY

Immersi-Prep Wands are backed by a one-year warranty. For more complete warranty terms and conditions, please call 1.800.437.4654 or visit vitamix.com.

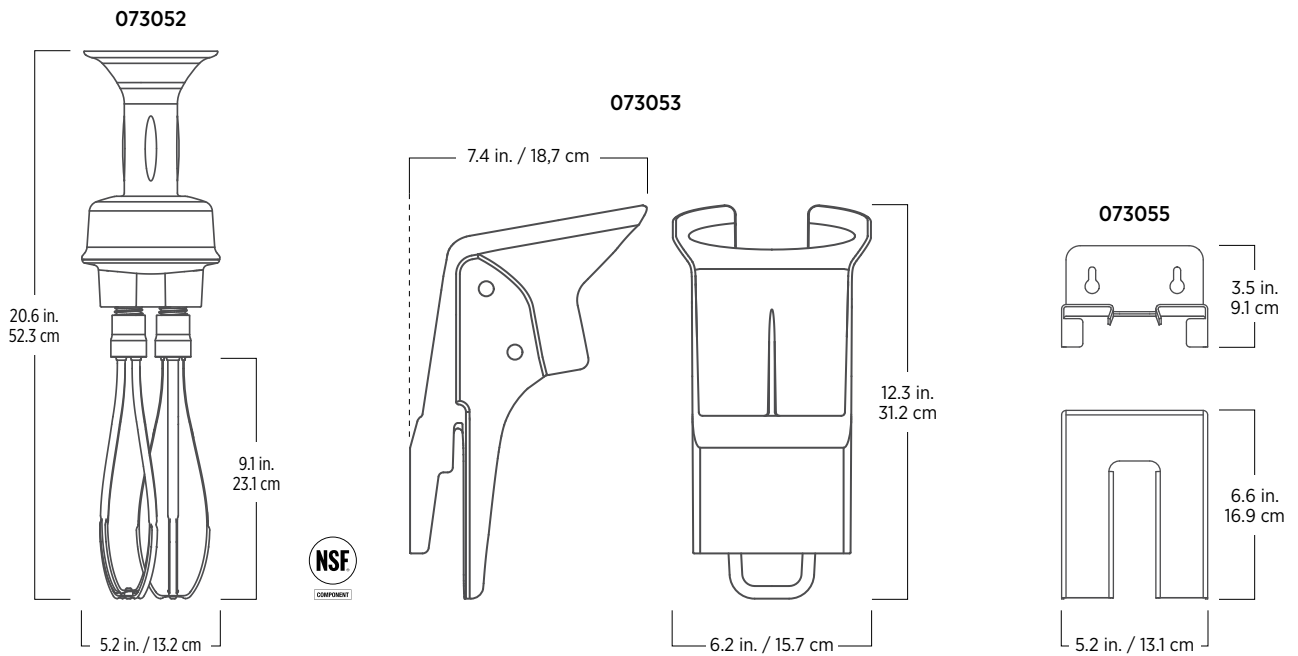

ITEM / MODEL #	DESCRIPTION
073052	Immersi-Prep Whisk includes whisk and Use & Care Manual.
073053	Immersi-Prep Pot Clip includes pot clip.
073055	Immersi-Prep Wall Mount includes wall mount.

SPECIFICATIONS

Dimensions (H x W x D):

073052: 20.6 x 5.2 x 5.2 in. / 52.3 x 13.2 x 13.2 cm

073053: 20.6 x 5.2 x 5.2 in. / 52.3 x 13.2 x 13.2 cm

073055: 20.6 x 5.2 x 5.2 in. / 52.3 x 13.2 x 13.2 cm

SHIPPING

Pack: 1 per standard pack

073052 Weight: 7.0 lbs.

073053 Weight: 3.1 lbs.

073055 Weight: 1.7 lbs.

Carton Dimensions (H x W x D):

073052: 14.6 x 14.7 x 7.1 in. / 37.1 x 37.3 x 18.0 cm

073053: 7.8 x 12.7 x 6.5 in. / 20.0 x 32.3 x 16.5 cm

073055: 4.5 x 6.7 x 6.7 in. / 11.4 x 17.1 x 17.1 cm

WARRANTY

The Immersi-Prep Whisk, Pot Clip, and Wall Mount are backed by a one-year warranty. For more complete warranty terms and conditions, please call 1.800.437.4654 or visit vitamix.com.

FROZEN TREAT MIXERS





MIX'N MACHINE® ADVANCE®

Programmed incorporating of mix-ins into ice cream and frozen yogurt

MIX'N MACHINE®

Standard incorporating of mix-ins into ice cream and frozen yogurt

APPLICATIONS

Frozen desserts with mix-ins
Milkshakes using either hard or soft ice cream

Frozen desserts with mix-ins
Milkshakes using either hard or soft ice cream

MOTOR

500 - 3000 RPM

3440 RPM

CONTROLS

6 programmed settings with gradual acceleration
Cup-activated lever
Pulse

On/Off Switch

ACCESSORIES

Variety of agitators available for different applications

Variety of agitators available for different applications

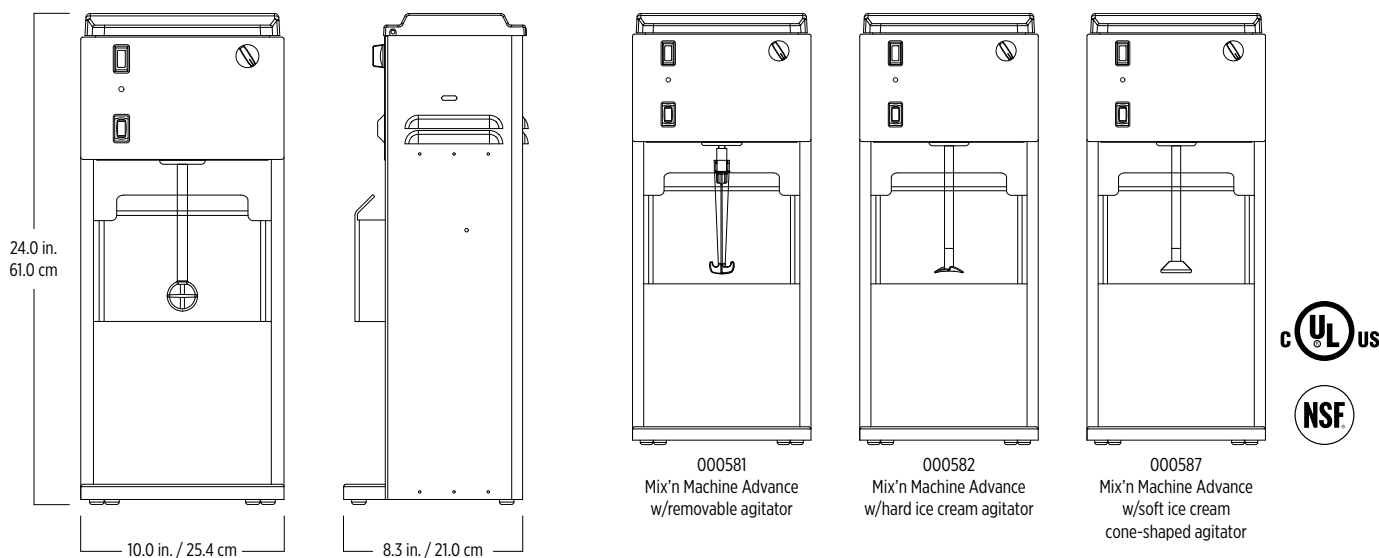

ITEM / MODEL #	DESCRIPTION
000580-895 / VM0805B	Mix'n Machine Advance with permanent soft ice cream agitator. Includes 6 pre-loaded programs.
000581-896 / VM0805B	Mix'n Machine Advance with removable / reusable agitator, includes 10 removable agitators. Includes 6 pre-loaded programs.
000582-897 / VM0805B	Mix'n Machine Advance with aggressive / permanent hard ice cream agitator. Includes 6 pre-loaded programs.
000587-2719 / VM0805B	Mix'n Machine Advance with permanent soft ice cream cone-shaped agitator. Includes 6 pre-loaded programs.

SPECIFICATIONS

Programs: 6

Motor: 500-3000 RPM bare motor speed

Electrical: 120 V, 50/60 Hz, 1.6 A

Dimensions (H x W x D):

24.0 x 10.0 x 8.3 in. / 61.0 x 25.4 x 21.0 cm

SHIPPING

Pack: 1 per standard pack

Weight: 21.65 lbs.

Carton Dimensions (H x W x D):

12.3 x 11.2 x 28.1 in. / 31.2 x 28.4 x 71.4 cm

WARRANTY

The Mix'n Machine Advance is backed by a three-year warranty on motor base parts and a one-year warranty on labor. For more complete warranty terms and conditions, please call 1.800.437.4654 or visit vitamix.com.

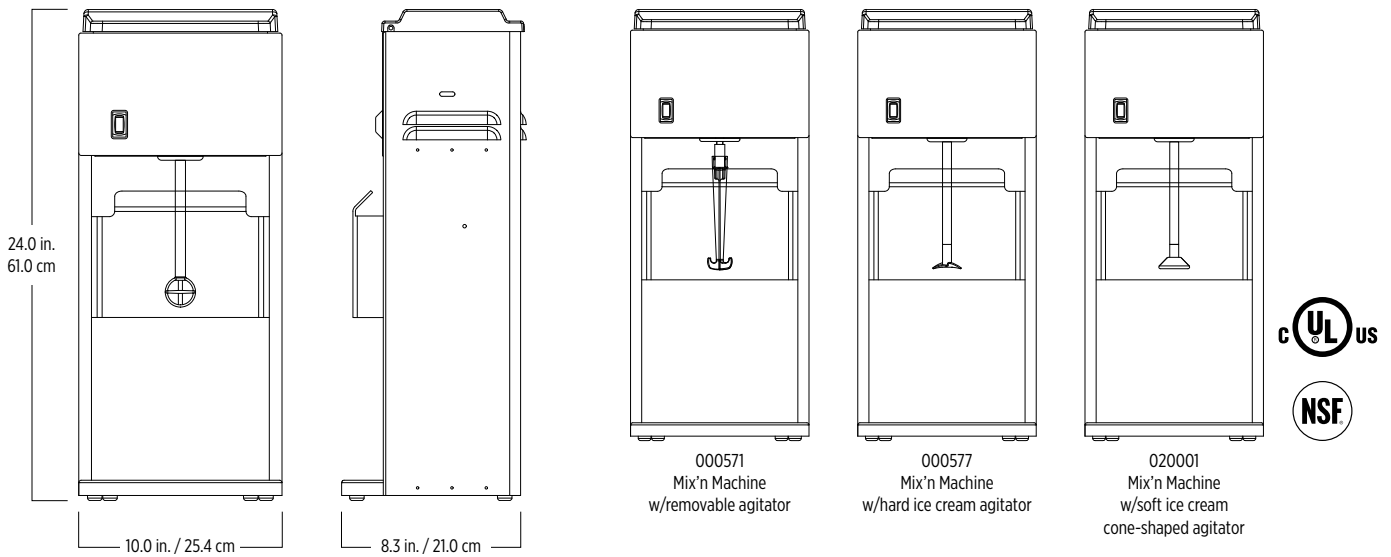

ITEM / MODEL #	DESCRIPTION
000570 / VM0800	Mix'n Machine On-Counter with permanent soft ice cream agitator.
000571 / VM0800A	Mix'n Machine On-Counter with removable / reusable agitator, includes 10 removable agitators.
000577 / VM0800	Mix'n Machine On-Counter with aggressive / permanent hard ice cream agitator.
020001 / VM0800	Mix'n Machine On-Counter with permanent soft ice cream cone-shaped agitator.

SPECIFICATIONS

Motor: 3440 RPM bare motor speed

Electrical: 120 V, 50/60 Hz, 2.6 A

Dimensions (H x W x D):

24.0 x 10.0 x 8.3 in. / 61.0 x 25.4 x 21.0 cm

SHIPPING

Pack: 1 per standard pack

Weight: 24.5 lbs.

Carton Dimensions (H x W x D):

12.2 x 11.1 x 28.0 in. / 30.9 x 28.2 x 71.1 cm

WARRANTY

The Mix'n Machine is backed by a three-year warranty on motor base parts and a one-year warranty on labor. For more complete warranty terms and conditions, please call 1.800.437.4654 or visit vitamix.com.

CONTAINERS

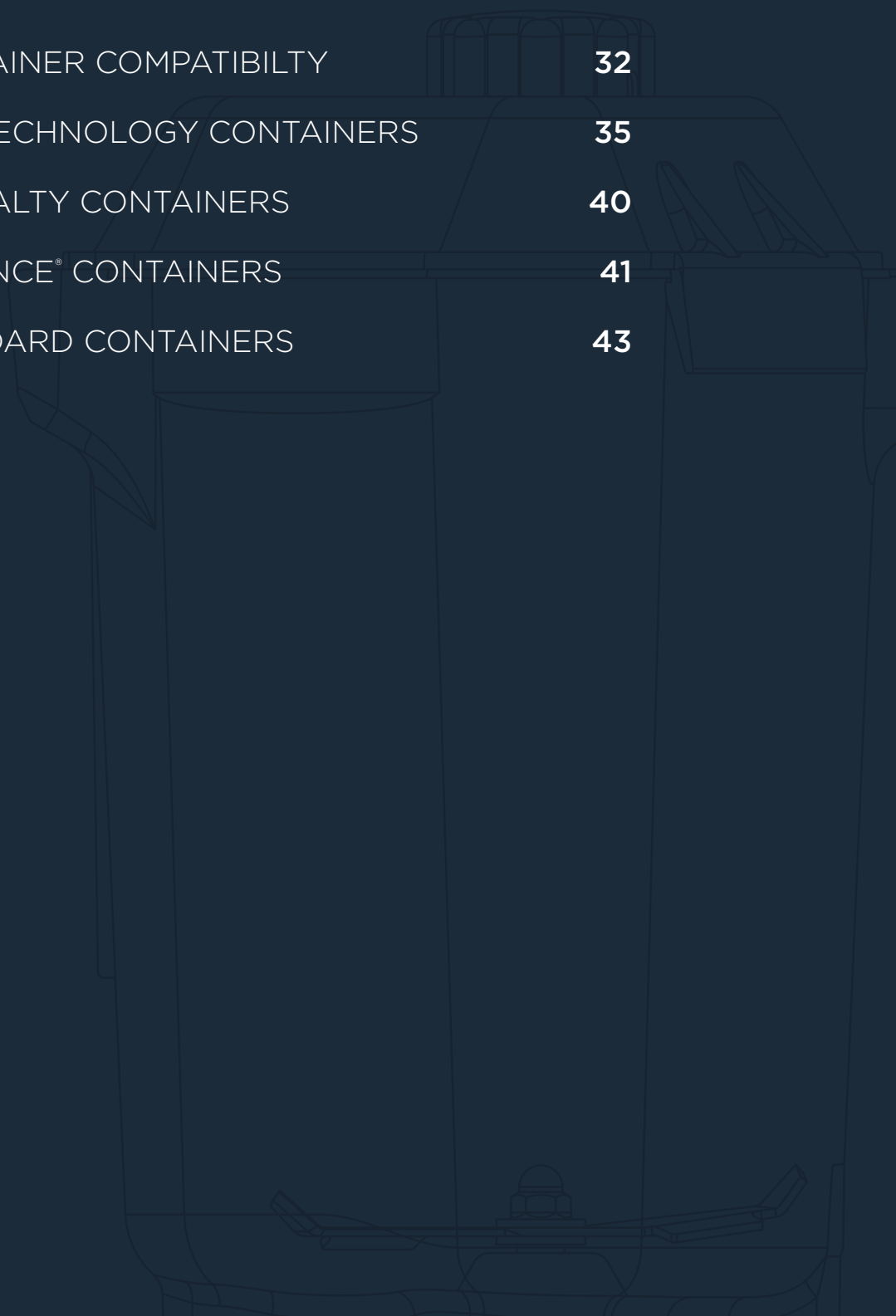

CONTAINER COMPATIBILITY	32
NFC TECHNOLOGY CONTAINERS	35
SPECIALTY CONTAINERS	40
ADVANCE® CONTAINERS	41
STANDARD CONTAINERS	43

COVERED BEVERAGE BLENDING

 Container comes standard
with the machine

 Container is compatible
and sold separately













Quick & Quiet®



The Quiet One®



Touch & Go® Advance®

Accelerate™ Container			
40-ounce			
Advance® Containers			
48-ounce			
32-ounce			
Standard Containers			
48-ounce			
32-ounce			
Specialty Containers			
48-ounce Aer® Blend			
32-ounce Aerating			

UNCOVERED BEVERAGE BLENDING

 Container comes standard
 with the machine

 Container is compatible
 and sold separately



Drink Machine Advance®



Drink Machine Two-Speed

Advance Containers

48-ounce



32-ounce



Standard Containers

64-ounce





48-ounce



32-ounce



FOOD PREPARATION BLENDING

 Container comes standard with the machine
 Container is compatible and sold separately



Power-Prep™



















Vita-Prep® 3



Vita-Prep®



Vitamix® XL®

NFC Technology Containers				
64-ounce Culinary				
1.5-gallon Big Batch™				
40-ounce Accelerate™ CE				
48-ounce Aer® Blend				
Standard Containers				
64-ounce				
48-ounce				
32-ounce				
Specialty Containers				
32-ounce Aerating				
1.5-gallon XL				
64-ounce XL				

Accelerate™ Container

- 40-ounce capacity with NFC technology.
- Innovative blending system completes recipes more efficiently with consistent results in record time.
- Features an innovative shape, and dual blade design that pull ingredients for more efficient and consistent blends.
- Heavy-duty retainer nut withstands high heat, extending blade assembly and container life.
- Compatible with Quick & Quiet® only.



40-OUNCE ACCELERATE CONTAINERS



<p>Complete</p> <p>40 oz. / 1.1 L BPA-Free, Accelerate Container complete with dual blade assembly and lid. NSF Certified. 2.8 lbs / 1.3 kg</p> <p>Dimensions (HxWxD): 10.2 x 7.0 x 9.0 in. / 25.9 x 17.7 x 22.8 cm</p>		<p>071774</p> <p>Model #: VM0227</p>	<p>071775</p> <p>Model #: VM0227</p>
<p>Container Only</p> <p>40 oz. / 1.1 L BPA-Free, Accelerate Container only, no blade assembly, no lid. NSF Certified. 1.4 lbs / 0.6 kg</p> <p>Dimensions (HxWxD): 8.1 x 7.0 x 9.0 in. / 20.5 x 17.7 x 22.8 cm</p>		<p>074651</p> <p>Model #: VM0227</p>	<p>074652</p> <p>Model #: VM0227</p>
<p>Splash Lid</p> <p>Splash lid for Accelerate Container. 6.4 oz. / 0.18 kg</p>		<p>074672</p>	<p>074671</p>
<p>Two Piece Lid</p> <p>Latching lid with lid plug, for Accelerate Container. 9.6 oz. / 0.3 kg</p>		<p>016043</p>	<p>N/A</p>
<p>Retainer Nut</p> <p>Retainer nut, for NFC containers. 9.6 oz. / 0.3 kg</p>		<p>065208</p>	
<p>Dual Blade Assembly</p> <p>Dual Advance blade assembly, for use with Accelerate container only. 6.4 oz. / 0.18 kg</p>		<p>075171</p>	

Aer[®] Blend Container

- Disc blade design creates dense and pourable culinary foam, flavored whipped cream, mousse, infusions, and emulsions with minimal splashing.
- BPA-Free Eastman Tritan™ and double-sealed bearings provide strength and durability.
- Non-latching splash lid enhances speed of service with easy on/off functionality and simplifies cleanup.
- Equipped with NFC smart technology to track container life and keep preventative maintenance up to date.
- Compatible with Quick & Quiet[®] and Power-Prep™ only.



48-OUNCE AER BLEND CONTAINER



<p>Complete</p> <p>48 oz. / 1.4 L compact BPA-Free, clear container with aerating blade assembly, and splash lid. NSF certified. 2.8 lbs. / 1.3 kg.</p> <p>Dimensions (H x W x D): 10.2 x 6.3 x 8.8 in. / 25.9 x 16.0 x 22.4 cm</p>		<p>075251</p> <p>Model #: VM0189</p>
<p>Container Only</p> <p>48 oz. / 1.4 L compact BPA-Free, clear container only. NSF certified. 1.82 lbs. / 0.83 kg.</p> <p>Dimensions (H x W x D): 9.2 x 6.3 x 8.8 in. / 25.9 x 16.0 x 22.4 cm</p>		<p>075253</p> <p>Model #: VM0189</p>
<p>Two Piece Lid</p> <p>Lid with lid plug for Aer Blend Container. 4.9 oz. / 0.14 kg</p>		<p>075252</p>
<p>Lid Plug</p> <p>Lid plug for 48 oz. / 1.4 L high-impact, clear / stackable container. 0.7 oz. / 0.02 kg</p>		<p>015987</p>
<p>Retainer Nut</p> <p>Retainer nut, for NFC containers. 9.6 oz. / 0.3 kg</p>		<p>065208</p>
<p>Aer Disc Assembly</p> <p>Aer disc blade assembly. 4.7 oz. / 0.13 kg</p>		<p>071911</p>

Culinary Container

- 64-ounce capacity with NFC technology.
- The classic Vitamix Commercial container, with precisely designed container and blade geometry that deliver fast, smooth blends.
- A removable lid plug allows you to add ingredients as you blend.
- BPA-free Eastman Tritan™ container and hardened stainless-steel blades.
- Designed for and compatible with Power-Prep™. Also compatible with Vita-Prep 3 and Vita-Prep.

64-OUNCE CULINARY CONTAINER



<p>Complete</p> <p>64 oz. / 2.0 L BPA-Free, clear container with NFC, wet blade assembly and lid. NSF certified. 2.7 lbs. / 1.2 kg.</p> <p>Dimensions (H x W x D): 13.1 x 6.2 x 7.9 in. / 33.3 x 15.7 x 20.0 cm</p>		<p>075761</p> <p>Model #: VM0248</p>
<p>Container Only</p> <p>64 oz. / 2.0 L BPA-Free, clear container with NFC only, no blade assembly, no lid. NSF certified. 2.4 lbs. / 1.1 kg.</p> <p>Dimensions (H x W x D): 10.8 x 6.2 x 7.9 in. / 27.4 x 15.7 x 20.0 cm</p>		<p>075775</p> <p>Model #: VM0248</p>
<p>Two Piece Lid</p> <p>Lid with lid plug, for 64 oz. / 2.0 L container. 7.2 oz. / 0.2 kg</p>		<p>001191</p>
<p>Lid Plug</p> <p>Lid plug, for 64 oz. / 2.0 L container. 1.6 oz. / 0.05 kg</p>		<p>062984</p>
<p>Retainer Nut</p> <p>Retainer nut, for NFC containers. 9.6 oz. / 0.3 kg</p>		<p>065208</p>
<p>Wet Blade Assembly</p> <p>Wet blade assembly. 6.4 oz. / 0.18 kg</p>		<p>071913</p>
<p>Tamper</p> <p>Tamper. 3.3 oz. / 0.09 kg</p>		<p>000760</p>

Big Batch™ Container

- 1.5-gallon capacity with NFC technology.
- Blends up to 24 8-ounce portions in one batch.
- Hardened stainless steel blades pulverize the toughest ingredients.
- Container made from BPA-free Eastman Tritan™.
- Compatible with Power-Prep™ only.



1.5-GALLON BIG BATCH CONTAINER

<p>Complete</p> <p>1.5 gal. / 5.6 L BPA-Free Tritan, clear container complete with NFC, wet blade assembly, lid and lid plug. NSF certified. 4.77 lbs. / 2.16 kg.</p> <p>Dimensions (H x W x D): 13.5 x 12.1 x 12 in. / 34.3 x 30.7 x 30.5 cm</p>		<p>075763</p> <p>Model #: VM0249</p>
<p>Container Only</p> <p>1.5 gal. / 5.6 L BPA-Free Tritan, clear container with NFC, no blade assembly, no lid, no lid plug. NSF certified. 1.66 lbs. / 0.75 kg.</p> <p>Dimensions (H x W x D): 12.1 x 8.8 x 12 in. / 30.7 x 22.4 x 30.5 cm</p>		<p>075776</p> <p>Model #: VM0249</p>
<p>Two Piece Lid</p> <p>Lid and lid plug, for use with Big Batch 1.5 gal. / 5.6 L container only. 1.45 lbs. / 0.66 kg</p>		<p>075780</p>
<p>Lid Plug</p> <p>Lid plug for use with NFC and Standard containers only. 1.6 oz. / 0.1 kg</p>		<p>062984</p>
<p>Retainer Nut</p> <p>Retainer nut, for NFC containers. 9.6 oz. / 0.3 kg</p>		<p>065208</p>
<p>Wet Blade Assembly</p> <p>Wet blade assembly. 6.4 oz. / 0.18 kg</p>		<p>071913</p>
<p>Tamper</p> <p>Tamper. 3.3 oz. / 0.09 kg</p>		<p>000760</p>

Accelerate™ Container CE

- 40-ounce capacity with NFC technology.
- Accelerate Container CE (Chef Edition) features a tamper-access lid, making it compatible with the standard Vitamix Commercial tamper size.
- Wider base for faster, more aggressive blending that efficiently pulls in ingredients while enhancing circulation.
- BPA-free Eastman Tritan™ container and hardened stainless-steel dual Advance® blade assembly.
- Compatible with Power-Prep™ only.



40-OUNCE ACCELERATE CONTAINER CE

<p>Complete</p> <p>40 oz. / 1.1 L BPA-Free, Accelerate Container complete with dual blade assembly and tamper-compatible lid. NSF Certified. 3.2 lbs / 1.5 kg</p> <p>Dimensions (HxWxD): 12.9 x 7.9 x 8.9 in. / 32.8 x 20.1 x 22.6 cm</p>		<p>075762</p> <p>Model #: VM0227</p>
<p>Container Only</p> <p>40 oz. / 1.1 L BPA-Free, Accelerate Container only, no blade assembly, no lid. NSF Certified. 1.4 lbs / 0.6 kg</p> <p>Dimensions (HxWxD): 8.1 x 7.0 x 9.0 in. / 20.5 x 17.7 x 22.8 cm</p>		<p>074651</p> <p>Model #: VM0227</p>
<p>Two Piece Lid</p> <p>Latching, tamper-compatible lid with lid plug, for Accelerate Container CE. 9.6 oz. / 0.3 kg</p>		<p>075779</p>
<p>Lid Plug</p> <p>Lid plug for use with NFC and Standard containers only. 1.6 oz. / 0.1 kg</p>		<p>062984</p>
<p>Retainer Nut</p> <p>Retainer nut, for NFC containers. 9.6 oz. / 0.3 kg</p>		<p>065208</p>
<p>Dual Blade Assembly</p> <p>Dual Advance blade assembly, for use with Accelerate container only. 6.4 oz. / 0.18 kg</p>		<p>075171</p>
<p>Tamper</p> <p>Tamper. 3.3 oz. / 0.09 kg</p>		<p>000760</p>



Aerating Container

- Disc blade design creates dense and pourable culinary foam, flavored whipped cream, mousse, infusions, and emulsions with minimal splashing.
- BPA-Free Eastman Tritan™ and double-sealed bearings provide strength and durability.
- Provides the flexibility to blend at a variety of speed settings.
- Compatible with The Quiet One®, Touch & Go® Advance®, Vita-Prep®, and Vita-Prep® 3.



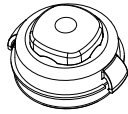

32-OUNCE AERATING CONTAINER

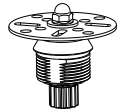
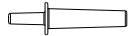

<p>Complete</p> <p>32 oz. / 0.9 L compact BPA-Free, clear / stackable container with aerating blade assembly, lid and mini tamper. NSF certified. 2.6 lbs. / 1.17 kg.</p> <p>Dimensions (H x W x D): 13.4 x 7.6 x 9.1 in. / 34.0 x 19.3 x 23.1 cm</p>		<p>062947</p> <p>Model #: VM0189</p>
<p>Two Piece Lid</p> <p>Latching lid with lid plug, for 32 oz. / 0.9 L compact, clear / stackable container. 5.7 oz. / 0.2 kg</p>		<p>015647</p>
<p>Lid Plug</p> <p>Lid plug for 32 oz. / 0.9 L compact clear / stackable container lid only. 1.7 oz. / 0.05 kg</p>		<p>015851</p>
<p>Retainer Nut</p> <p>Retainer nut, for standard containers. 1.0 lb. / 0.45 kg</p>		<p>000836</p>
<p>Aer Disc Assembly</p> <p>Aer disc blade assembly. 4.7 oz. / 0.13 kg</p>		<p>071911</p>
<p>Mini Tamper</p> <p>Mini Tamper. 2.0 oz. / 0.06 kg</p>		<p>015033</p>

48-OUNCE ADVANCE CONTAINERS

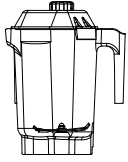
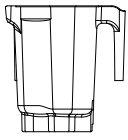

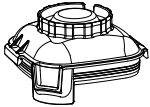
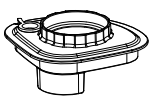
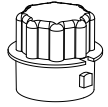
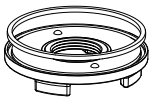
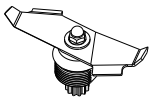
<p>Complete 48 oz. / 1.4 L BPA-Free, Advance Container complete with Advance blade assembly and lid. NSF certified. 2.2 lbs. / 1.0 kg Dimensions (H x W x D): 10.5 x 7.1 x 8.2 in. / 26.7 x 18.0 x 20.8 cm</p>		<p>015978 Model #: VM0143B</p>	<p>058988 Model #: VM0143B</p>	<p>058989 Model #: VM0143B</p>	<p>058990 Model #: VM0143B</p>	<p>058991 Model #: VM0143B</p>
<p>Container Only 48 oz. / 1.4 L BPA-Free, Advance Container only, no blade assembly, no lid. NSF certified. 1.0 lbs. / 0.45 kg Dimensions (H x W x D): 8.6 x 7.1 x 8.2 in. / 21.8 x 18.0 x 20.8 cm</p>		<p>016016 Model #: VM0143B</p>	<p>060048 Model #: VM0143B</p>	<p>060049 Model #: VM0143B</p>	<p>060050 Model #: VM0143B</p>	<p>060051 Model #: VM0143B</p>
<p>Two Piece Lid Latching lid with lid plug, for Advance Container. 7.2 oz. / 0.2 kg</p>		<p>015985</p>	<p>N/A</p>	<p>N/A</p>	<p>N/A</p>	<p>N/A</p>
<p>One Piece Lid Latching one-piece lid, for Advance Container. 7.2 oz. / 0.2 kg</p>		<p>016090</p>	<p>058992</p>	<p>058993</p>	<p>058994</p>	<p>058995</p>
<p>Splash Lid Splash lid with tethered lid plug, for Advance Container. 6.0 oz. / 0.17 kg</p>		<p>015092</p>	<p>058996</p>	<p>058997</p>	<p>058998</p>	<p>058999</p>
<p>Lid Plug Lid plug, for Advance Container. 0.7 oz. / 0.02 kg</p>		<p>015987</p>	<p>N/A</p>	<p>N/A</p>	<p>N/A</p>	<p>N/A</p>
<p>Retainer Nut Advance retainer nut, for Advance Container. 3.6 oz. / 0.1 kg</p>		<p>015585</p>				
<p>Advance Blade Assembly Advance blade assembly, for use with Advance Container only. 8.5 oz. / 0.24 kg</p>		<p>015990</p>				





32-OUNCE ADVANCE CONTAINERS

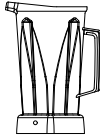
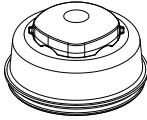
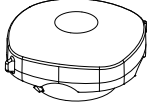

<p>Complete 32 oz. / 0.9 L BPA-Free, Advance Container complete with Advance blade assembly and lid. NSF certified. 2.2 lbs. / 1.0 kg. Dimensions (H x W x D): 10.5 x 7.1 x 8.2 in. / 26,7 x 18,0 x 20,8 cm</p>		<p>015981 Model #: VM0143C</p>	<p>058984 Model #: VM0143C</p>	<p>058985 Model #: VM0143C</p>	<p>058986 Model #: VM0143C</p>	<p>058987 Model #: VM0143C</p>
<p>Container Only 32 oz. / 0.9 L BPA-Free, Advance Container only, no blade assembly, no lid. NSF certified. 1.0 lb. / 0.45 kg. Dimensions (H x W x D): 8.6 x 7.1 x 8.2 in. / 21,8 x 18,0 x 20,8 cm</p>		<p>016019 Model #: VM0143C</p>	<p>060044 Model #: VM0143C</p>	<p>060045 Model #: VM0143C</p>	<p>060046 Model #: VM0143C</p>	<p>060047 Model #: VM0143C</p>
<p>Two Piece Lid Latching lid with lid plug, for Advance Container. 7.2 oz. / 0.2 kg</p>		<p>015985</p>	<p>N/A</p>	<p>N/A</p>	<p>N/A</p>	<p>N/A</p>
<p>One Piece Lid Latching one-piece lid, for Advance Container. 7.2 oz. / 0.2 kg</p>		<p>016090</p>	<p>058992</p>	<p>058993</p>	<p>058994</p>	<p>058995</p>
<p>Splash Lid Splash lid with tethered lid plug, for Advance Container. 6.0 oz. / 0.17 kg</p>		<p>015092</p>	<p>058996</p>	<p>058997</p>	<p>058998</p>	<p>058999</p>
<p>Lid Plug Lid plug, for Advance Container. 0.7 oz. / 0.02 kg</p>		<p>015987</p>	<p>N/A</p>	<p>N/A</p>	<p>N/A</p>	<p>N/A</p>
<p>Retainer Nut Advance retainer nut, for Advance Container. 3.6 oz. / 0.1 kg</p>		<p>015585</p>				
<p>Advance Blade Assembly Advance blade assembly, for use with Advance Container only. 8.5 oz. / 0.24 kg</p>		<p>015990</p>				

64-OUNCE STANDARD CONTAINERS

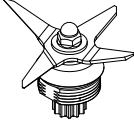

<p>Complete</p> <p>64 oz. / 2.0 L BPA-Free, clear container with wet blade assembly and lid. NSF certified. 3.2 lbs. / 1.5 kg.</p> <p>Dimensions (H x W x D): 12.8 x 6.0 x 7.9 in. / 32.5 x 15.2 x 20.0 cm</p>		<p>001195 Model #: VM0135</p>	<p>067403 Model #: VM0135</p>
<p>Container Only</p> <p>64 oz. / 2.0 L BPA-Free, clear container only, no blade assembly, no lid. NSF certified. 2.4 lbs. / 1.1 kg.</p> <p>Dimensions (H x W x D): 10.8 x 6.0 x 7.9 in. / 27.4 x 15.2 x 20.0 cm</p>		<p>058625 Model #: VM0135</p>	<p>067404 Model #: VM0135</p>
<p>Two Piece Lid</p> <p>Lid with lid plug, for 64 oz. / 2.0 L container. 7.2 oz. / 0.2 kg</p>		<p>001191</p>	<p>067405</p>
<p>Lid Plug</p> <p>Lid plug, for 64 oz. / 2.0 L container. 1.6 oz. / 0.05 kg</p>		<p>062984</p>	<p>N/A</p>
<p>Retainer Nut</p> <p>Retainer nut, for standard containers. 1.0 lb. / 0.45 kg</p>		<p>000836</p>	
<p>Wet Blade Assembly</p> <p>Wet blade assembly. 6.4 oz. / 0.18 kg</p>		<p>001152</p>	
<p>Tamper</p> <p>Tamper. 3.3 oz. / 0.09 kg</p>		<p>000760</p>	

48-OUNCE STANDARD CONTAINER



32-OUNCE STANDARD CONTAINER



<p>Complete 48 oz. / 1.4 L BPA-Free, clear / stackable container with wet blade assembly and lid. NSF certified. 2.0 lbs. / 0.9 kg.</p> <p>Dimensions (H x W x D): 10.0 x 6.2 x 7.6 in. / 25.4 x 15.7 x 19.3 cm</p>		<p>015504 Model #: VM0136</p>
<p>Container Only 48 oz. / 1.4 L BPA-Free, clear / stackable container only, no blade assembly, no lid. NSF certified. 1.3 lbs. / 0.6 kg.</p> <p>Dimensions (H x W x D): 9.2 x 6.2 x 7.6 in. / 23.4 x 15.7 x 19.3 cm</p>		<p>058805 Model #: VM0136</p>
<p>Two Piece Lid Latching lid with lid plug, for 48 oz. / 1.4 L clear / stackable container. 4.8 oz. / 0.13 kg</p>		<p>015507</p>
<p>Lid Plug Lid plug for 48 oz. / 1.4 L clear / stackable container. 0.7 oz. / 0.02 kg</p>		<p>015987</p>
<p>Retainer Nut Retainer nut, for standard containers. 1.0 lb. / 0.45 kg</p>		<p>000836</p>
<p>Wet Blade Assembly Wet blade assembly. 6.4 oz. / 0.18 kg</p>		<p>001152</p>
<p>Tamper Tamper. 3.3 oz. / 0.09 kg</p>		<p>000760</p>

<p>Complete 32 oz. / 0.9 L compact BPA-Free, clear / stackable container with wet blade assembly and lid. NSF certified. 2.6 lbs. / 1.2 kg.</p> <p>Dimensions (H x W x D): 10.2 x 5.6 x 8.2 in. / 26.0 x 14.2 x 20.8 cm</p>		<p>015652 Model #: VM0137</p>
<p>Container Only 32 oz. / 0.9 L compact BPA-Free, clear / stackable container only, no blade assembly, no lid. NSF certified. 1.8 lbs. / 0.8 kg.</p> <p>Dimensions (H x W x D): 8.1 x 5.6 x 8.2 in. / 20.5 x 14.2 x 20.8 cm</p>		<p>015643 Model #: VM0137</p>
<p>Two Piece Lid Latching lid with lid plug, for 32 oz. / 0.9 L compact, clear / stackable container. 5.7 oz. / 0.2 kg</p>		<p>015647</p>
<p>Lid Plug Lid plug for 32 oz. / 0.9 L compact clear / stackable container lid only. 1.7 oz. / 0.05 kg</p>		<p>015851</p>
<p>Retainer Nut Retainer nut, for standard containers. 1.0 lb. / 0.45 kg</p>		<p>000836</p>
<p>Wet Blade Assembly Wet blade assembly. 6.4 oz. / 0.18 kg</p>		<p>001152</p>
<p>Mini Tamper Tamper. 2.0 oz. / 0.06 kg</p>		<p>015033</p>

STANDARD XL CONTAINERS

1.5-GALLON FOR XL



64-OUNCE FOR XL



<p>Complete</p> <p>1.5 gal. / 5.6 L container complete with XL blade assembly, lid and lid plug. For use with Vitamix XL only. NSF certified.</p> <p>5.03 lbs. / 2.28 kg.</p> <p>Dimensions (H x W x D): 13.3 x 12.1 x 12.1 in. / 33.4 x 30.7 x 30.7 cm</p>		<p>015899-1206</p> <p>Model #: VM0142</p>
<p>Container Only</p> <p>1.5 gal. / 5.6 L container only, no blade assembly, no lid, no lid plug. For use with Vitamix XL only. NSF certified.</p> <p>1.66 lbs. / 0.75 kg.</p> <p>Dimensions (H x W x D): 12.0 x 8.8 x 12.1 in. / 30.5 x 22.4 x 30.7 cm</p>		<p>015896</p> <p>Model #: VM0142</p>
<p>Two Piece Lid</p> <p>Latching lid and lid plug, for 1.5 gal. / 5.6 L XL container only.</p> <p>1.45 lbs. / 0.66 kg</p>		<p>015900</p>
<p>Lid Plug</p> <p>Lid plug for use with Vitamix XL containers only.</p> <p>1.6 oz. / 0.1 kg</p>		<p>062984</p>
<p>Retainer Nut</p> <p>Retainer nut, for use with Vitamix XL 1.5 gal. / 5.6 L container only.</p> <p>1.10 lbs. / 0.5 kg</p>		<p>015901</p>
<p>XL Blade for use with 1.5-gallon container</p> <p>Blade assembly, for use with Vitamix XL 1.5 gal. / 5.6 L container only.</p> <p>13.4 oz. / 0.38 kg</p>		<p>015897</p>
<p>Tamper</p> <p>Tamper.</p> <p>3.3 oz. / 0.09 kg</p>		<p>000760</p>

<p>Complete</p> <p>64 oz. / 2.0 L container complete with XL blade assembly, lid and lid plug. For use with Vitamix XL only. NSF certified.</p> <p>3.2 lbs. / 1.45 kg.</p> <p>Dimensions (H x W x D): 13.1 x 7.1 x 8.2 in. / 33.3 x 18.0 x 20.8 cm</p>		<p>015894-1205</p> <p>Model #: VM0143</p>
<p>Container Only</p> <p>64 oz. / 2.0 L container only, no blade assembly, no lid, no lid plug. For use with Vitamix XL only. NSF certified.</p> <p>1.0 lb. / 0.45 kg.</p> <p>Dimensions (H x W x D): 8.6 x 7.1 x 8.2 in. / 21.8 x 18.0 x 20.8 cm</p>		<p>015893</p> <p>Model #: VM0143</p>
<p>Two Piece Lid</p> <p>Latching lid and lid plug, for 64 oz. / 2.0 L XL container only.</p> <p>1.05 lbs. / 0.48 kg</p>		<p>015892</p>
<p>Lid Plug</p> <p>Lid plug for use with Vitamix XL containers only.</p> <p>1.6 oz. / 0.1 kg</p>		<p>062984</p>
<p>Retainer Nut</p> <p>Retainer nut, for use with Vitamix XL 64 oz. / 2.0 L container only.</p> <p>11.2 oz. / 0.32 kg</p>		<p>015942</p>
<p>XL Blade for use with 64-ounce container</p> <p>Blade assembly, for use with Vitamix XL 64 oz. / 2.0 L container only.</p> <p>7.2 oz. / 0.20 kg</p>		<p>015941</p>
<p>Tamper</p> <p>Tamper.</p> <p>3.3 oz. / 0.09 kg</p>		<p>000760</p>

ACCESSORIES & PARTS

ACCESSORIES

RINSERS 47

PARTS

RINSERS 49

PROGRAMMING 49

SOUND ENCLOSURES 50

CENTERING PADS 50

DRIVE SOCKETS, REPAIR KITS 51

IMMERSI-PREP™ 52

MIX'N MACHINE® 52



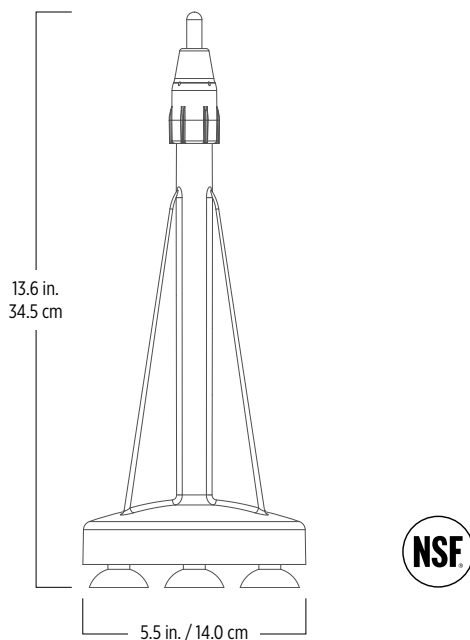

ITEM / MODEL #	DESCRIPTION
001442 / VM0134	Rinse-O-Matic blender container rinser, includes base, 2.5 ft. / 76.2 cm hose assembly, Y connector, faucet adapters and instructions.
001445 / VM0134	Rinse-O-Matic blender container rinsers, carton of 12.

SPECIFICATIONS

PSI: Cold water from a faucet with a minimum 25 psi / maximum 80 psi of pressure

Dimensions (H x W x D):
13.6 x 5.5 x 5.5 in. / 34.5 x 14.0 x 14.0 cm

SHIPPING

1442 Pack: 1 per standard pack

1442 Weight: 2.1 lbs.

1445 Pack: 12 per standard pack

1445 Weight: 27.95 lbs.

Carton Dimensions (H x W x D):

1442: 14.2 x 6.9 x 6.6 in. / 36.1 x 17.5 x 16.8 cm

1445: 14.75 x 20.75 x 27.75 in. / 37.5 x 52.7 x 70.5 cm

WARRANTY

The Rinse-O-Matic is backed by a one-year warranty on parts. For more complete warranty terms and conditions, please call 1.800.437.4654 or visit vitamix.com.

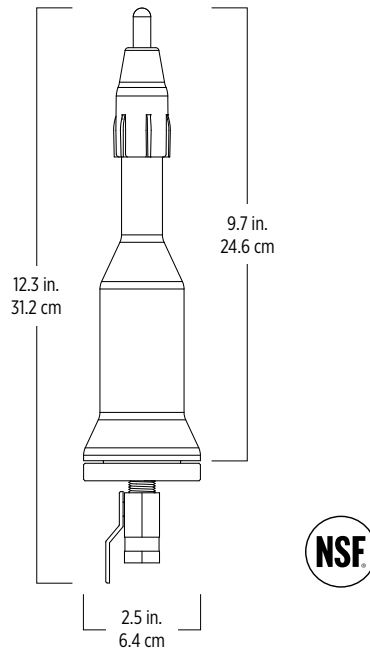

ITEM / MODEL #	DESCRIPTION
001462	Sink Mount Rinse-O-Matic blender container rinser includes base, valve, and instructions.

SPECIFICATIONS

PSI: Cold water from a faucet with a minimum 25 psi / maximum 80 psi of pressure

Dimensions (H x W x D):
12.3 x 2.5 x 2.5 in / 31.2 x 6.4 x 6.4 cm

*A 1¾" diameter hole must be drilled in sink to allow for installation.

SHIPPING

Pack: 1 per standard pack

Weight: 1.15 lbs.

Carton Dimensions (H x W x D):

15.2 x 11.4 in. / 38.7 x 28.9 cm

WARRANTY

The Sink Mount Rinse-o-matic is backed by a one-year warranty on parts. For more complete warranty terms and conditions, please call 1.800.437.4654 or visit vitamix.com.

Find Your Accessories

Locate your machine in the following charts to find replacement parts and compatible accessories.



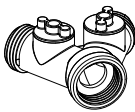
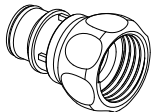
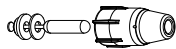
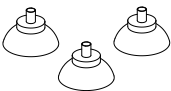
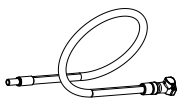

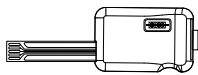
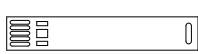

RINSERS — REPLACEMENT PARTS

Rinse-O-Matic®	001415		Faucet adapter kit, includes various adapters - 5 per standard pack. 2.3 oz. / 0.06 kg
Rinse-O-Matic®	001419		Y faucet connector. 4.9 oz. / 0.13 kg
Rinse-O-Matic®	001437		Quick disconnect insert (male). 0.5 oz. / 0.01 kg
Rinse-O-Matic® In Sink Rinse-O-Matic®	001443		Rinse-O-Matic sprayhead / activator replacement kit, includes sprayhead and valve assembly. 0.64 oz. / 0.02 kg
Rinse-O-Matic®	001444		Feet replacement kit, includes rubber suction cup feet - 3 per standard pack. 0.4 oz. / 0.01 kg
Rinse-O-Matic®	001448		Rinse-O-Matic hose assembly replacement kit, includes 2.5 ft. / 76,2 cm clear PVC hose, and 2 connectors. 5.4 oz. / 0.15 kg

PROGRAMMING — REPLACEMENT PARTS

Quick & Quiet® The Quiet One® Drink Machine™ Advance® XL® Programs Mix'n Machine® Advance®	015606		Programmer software kit for the Q&Q, TQO, DMA, and MMA.
	015644		Extra program chip for programmer software kit.
	015645		Extra program chips for programmer software kit - 10 per standard package.



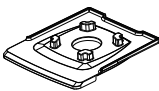
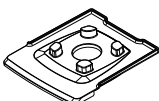
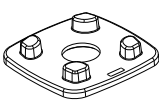
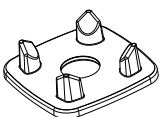
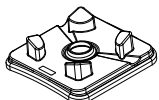
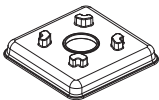

SOUND ENCLOSURES — REPLACEMENT PARTS

Quick & Quiet®	073311		Complete two-piece Twist Lock copolyester plastic compact cover with removable cover hinge. For Quick & Quiet only.
	074611		Twist Lock copolyester plastic compact cover back only. For Quick & Quiet only.
	074612		Copolyester plastic compact cover door and handle only. For Quick & Quiet only.
The Quiet One® (Twist Lock) Touch & Go Advance	067879		Complete two-piece Twist Lock copolyester plastic compact cover with removable cover hinge. For The Quiet One Twist Lock and Touch & Go Advance only.
	067877		Twist Lock copolyester plastic compact cover back only. For The Quiet One Twist Lock and Touch & Go Advance only.
	015081		Copolyester plastic compact cover door only. For The Quiet One Twist Lock and Touch & Go Advance only.

CENTERING PADS — REPLACEMENT PARTS

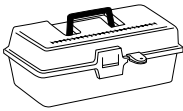
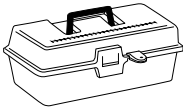
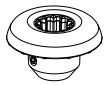
Quick & Quiet®	073553		Sound-reducing centering pad, for Quick & Quiet. 6.4 oz. / 0.18 kg
The Quiet One® (Twist Lock) Touch & Go Advance	067876		Sound-reducing centering pad, for TQO (Twist Lock) and Touch & Go Advance. 3.5 oz. / 0.09 kg
Drink Machine™ Advance®	015578		Sound-reducing centering pad, for Drink Machine Advance. 3.5 oz. / 0.09 kg
Drink Machine™ Two-Speed Vita-Prep® 3 Vita-Prep®	000791		Sound-reducing centering pad. 4.0 oz. / 0.11 kg
XL® Variable Speed XL® Programs	015895		Sound-reducing centering pad, for Vitamix XL, 1 per standard pack. 3.5 oz. / 0.09kg
Power-Prep™	075772		Sound-reducing centering pad, for Power-Prep. 5.6 oz. / 0.16 kg

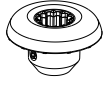
DRIVE SOCKET, REPAIR KITS — REPLACEMENT PARTS

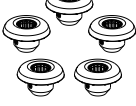
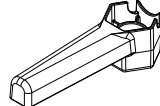
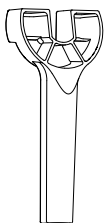
<p>Quick & Quiet® Power-Prep™</p>	<p>075571</p>		<p>Repair kit with tool box, includes 5 drive sockets, retainer nut wrench, silicone sealant tube, Allen wrench, and maintenance manual. 3.0 lbs. / 1.3 kg</p>
<p>The Quiet One® Touch and Go Advance Drink Machine™ Advance® Drink Machine™ Two-Speed Vita-Prep® 3 / Vita-Prep®</p>	<p>015519</p>		<p>Repair kit with tool box, includes 5 drive sockets, retainer nut wrench, silicone sealant tube, Allen wrench, and maintenance manual. 3.0 lbs. / 1.3 kg</p>
<p>Quick & Quiet® The Quiet One® Touch and Go Advance Drink Machine™ Advance® Drink Machine™ Two-Speed Power-Prep™ Vita-Prep® 3 Vita-Prep® Immersi-Prep™</p>	<p>000891</p>		<p>Drive socket kit with 1 drive socket, includes Allen wrench and instructions. 1.6 oz. / 0.04 kg</p>
	<p>015546</p>		<p>Drive socket kit with 2 drive sockets, includes Allen wrench and instructions. 2.0 oz. / 0.05 kg</p>
	<p>015547</p>		<p>Drive socket kit with 5 drive sockets, includes Allen wrench and instructions. 4.0 oz. / 0.11 kg</p>
<p>XL® Variable Speed XL® Programs</p>	<p>015902</p>		<p>Drive socket kit with 1 drive socket, includes Allen wrench and instructions. For use with Vitamix XL only. 1.6 oz. / 0.04 kg</p>
	<p>015903</p>		<p>Drive socket kit with 2 drive sockets, includes Allen wrench and instructions. For use with Vitamix XL only. 2.0 oz. / 0.05 kg</p>
	<p>015904</p>		<p>Drive socket kit with 5 drive sockets, includes Allen wrench and instructions. For use with Vitamix XL only. 4.0 oz. / 0.11 kg</p>
<p>Quick & Quiet® Power-Prep™</p>	<p>073652</p>		<p>Retainer nut wrench, plastic. 3.2 oz. / 0.09 kg</p>
<p>The Quiet One® Touch and Go Advance Drink Machine™ Advance® Drink Machine™ Two-Speed Vita-Prep® 3 / Vita-Prep® XL® Variable Speed / Programs</p>	<p>015596</p>		<p>Retainer nut wrench, plastic. 3.2 oz. / 0.09 kg</p>

IMMERSI-PREP — REPLACEMENT PARTS

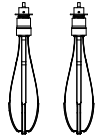
Immersi-Prep™	075197		Replacement whisk beaters. 1.38 lbs. / 0.63 kg
---------------	---------------	---	---

MIX'N MACHINE | MIX'N MACHINE ADVANCE — REPLACEMENT PARTS

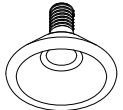
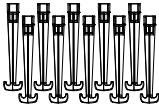
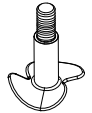
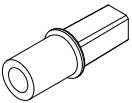
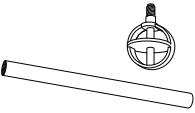
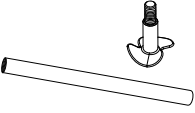
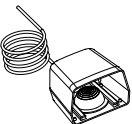
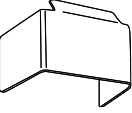
Mix'n Machine® Mix'n Machine® Advance®	030019		Permanent soft ice cream agitator. 0.8 oz. / 0.02 kg
Mix'n Machine® Mix'n Machine® Advance®	030060		Permanent soft ice cream cone-shaped agitator. 0.8 oz. / 0.02 kg
Mix'n Machine® Mix'n Machine® Advance®	030003		Removable agitators - 10 per standard pack. 0.4 oz. / 0.01 kg Note: Must be used with removable agitator shaft.
Mix'n Machine® Mix'n Machine® Advance®	030018		Aggressive / permanent hard ice cream agitator. 0.8 oz. / 0.02 kg
Mix'n Machine® Mix'n Machine® Advance®	000080		Conversion kit: permanent soft / hard ice cream agitator to removable / reusable agitator. Contains 1 removable agitator shaft. 2.5 oz. / 0.07 kg
Mix'n Machine® Mix'n Machine® Advance®	000081		Conversion kit for on-counter models: removable / reusable agitator to permanent soft ice cream agitator. Contains 1 permanent soft ice cream agitator (#30019), and 1 countertop agitator shaft (#30023). 2.5 oz. / 0.07 kg
Mix'n Machine® Mix'n Machine® Advance®	030006		Conversion kit: removable / reusable agitator to aggressive / permanent hard ice cream agitator. Contains 1 permanent hard ice cream agitator (#30018), and 1 countertop agitator shaft (#30023). 3.4 oz. / 0.09 kg
Mix'n Machine®	030000		Guarded air-activated foot control for 120 V models only. 2.2 lbs. / 0.1 kg
Mix'n Machine® Mix'n Machine® Advance®	030015		Splash guard for on-counter models. 9.5 oz. / 0.3 kg

MIX'N MACHINE | MIX'N MACHINE ADVANCE — REPLACEMENT PARTS

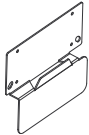
<p>Mix'n Machine® Mix'n Machine® Advance®</p>	<p>030023</p>		<p>Agitator shaft for standard on-counter models. 4.8 oz. / 0.14 kg</p>
<p>Mix'n Machine® Mix'n Machine® Advance®</p>	<p>015668</p>		<p>Wall mounting (bracket) kit. 2.0 lbs / 0.9 kg</p>

TO PLACE AN ORDER:

(Choose one of the following methods)



By Email:

commercial@vitamix.com



By Fax:

[+1 440.235.9670](tel:+14402359670)

REQUIRED INFORMATION ON ORDERS:

Vitamix requires that all purchase orders accurately identify the following minimum information:

- Vitamix account number
- P.O. number
- Payment terms
- Bill to address: business name, street address, city, state, zip code, phone number, fax number or email address, and primary contact person
- Ship to address: business name, street address, city, state, zip code, phone number, fax number or email address, and a contact person (**Note: orders can not be shipped to a P.O. Box**)
- Requested delivery date
- Preferred shipping method
- Vitamix item number
- Item number description
- Quantity per item number being ordered

TERMS:

- This catalog contains U.S. 120V Vitamix products that are only applicable for sale in the U.S.
- The exporting of U.S. Vitamix products is strictly prohibited and voids all warranty.
- Unilateral Distribution Policy - Vitamix will not do business with any reseller that advertises, offers, or sells any Vitamix Commercial product at a net retail sales price that is more than 50/10/5% below Vitamix's current Published List Price for such product (the "Floor Price").
- Reselling - Vitamix Commercial prohibits the reselling of products to Amazon and/or selling to or advertising on Walmart.com
- All prices are in U.S. dollars and are subject to change without notice.
- All orders are subject to acceptance by Vitamix.
- A minimum order of \$50.00 is required.
- Any single order in excess of \$6000 Net (\$7500 Net when ordering an XL or Quick & Quiet) shipping to the same destination within the contiguous United States of America will receive free ground shipping via the carrier chosen by Vitamix.
- All orders that do not include specific shipping instructions will be shipped via ground freight by the carrier chosen by Vitamix.
- Shipping and handling charges will be applied to each order based on the standard rates charged by the selected carrier.
- A drop ship fee of \$15.00 per order applies when shipping machines to a different destination than the billing address.
- Vitamix is not liable for any type of theft or fraud related to drop ship orders. Signature required is recommended on all drop ship orders. Additional fee applies.

TO PLACE AN ORDER:

(Continued)

- All air shipment charges are the responsibility of the requester and will be included in the shipping and handling fees.
- EXW Cleveland, Ohio U.S.A. Net 30 days from date of invoice with approved credit. Allow 10 business days for credit application to process.
- 1.5% monthly (18% annually) service charge added on all accounts past due.
- \$20.00 fee charged for all returned checks.

DAMAGES AND SHORTAGES / RETURNS FREIGHT:

- Inspect your shipment immediately. The transportation company is responsible for the merchandise while it is in transit to you.
- If there is a shortage or damage to your shipment, action must be taken by you to notify the carrier upon arrival of shipment to ensure approval of claim. It is the duty and responsibility of the delivering carrier to give you a written report of such shortage or damage following notification.
- Concealed damage: If the damage is concealed, notify the carrier within 48 hours, by phone and in writing, asking them to send their agent to complete an inspection report. Retain all cartons and merchandise for their inspection report and claim approval. It is critical that you file a written claim with the carrier within 48 hours of receipt of shipment for any shortage or concealed damage. Enclose with your claim: Carrier's Inspection Report, paid freight bill and original or certified copy of invoice.

RETURNS:

- Before returning any product, please contact our customer service department at 1.800.4DRINK4. Vitamix is not responsible for items returned without authorization.
- Goods may not be returned without a return authorization (RA) number from Vitamix.
- All cartons returned must be marked with the return authorization number. In order for merchandise to be returned, it should be in the original carton and unopened.
- Absolutely no returns will be accepted after 120 days of ship date.
- Special merchandise built to a buyer's specification may not be returned.
- Returned goods must be shipped to Vitamix prepaid and will be credited at invoice less 20% restocking charge.
- The restocking charge will be reduced to 10% if a replacement unit is ordered at time of return.

CONTACT:

U.S.A.

Phone: 800.437.4654

Fax: +1 440.235.9670

Email: commercial@vitamix.com

Outside U.S.A.

Phone: +1 440.782.2450

Fax: +1 440.782.2220

Email: international@vitamix.com

For more information on international products, please contact Vitamix.

Warranties listed in this price book are applicable to the United States only. Please see the owner's manual for complete warranty details. For equipment and warranties outside of the United States, contact a Vitamix authorized international distributor or contact Vitamix for a distributor near you.

Any other use or distribution of this price list, direct or indirect, or the information herein without the written permission of Vita-Mix® Corporation is forbidden.

WE'RE HERE TO HELP

SALES SUPPORT

Our passion for world-class customer service runs deep within our roots as a company. Our dedicated sales representatives are here to answer all of your product questions, please email commercial@vitamix.com.

TECHNICAL SUPPORT

Please reach out to our Commercial Customer Service team in Cleveland, Ohio at commercialts@vitamix.com

